

# XL46-XL461 MACHINECARD

DATE

CUSTOMER



## MACHINE TYPE

XL46 ( head starting from bottom ) - suggested for high boxes

XL461 ( head starting from top ) - suggested for low boxes

XL046 ( taping only bottom part ) - suggested for low boxes

**XL46 Range** : Semi-Automatic Random Cartons Sealing Machines

### XL46

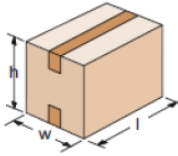

#### Standard

Taping Head K12/70	L	W	H
Min.	150	140	120*
Max.	∞	650	650

Taping Head K12/50	L	W	H
Min.	150	140	120*
Max.	∞	650	650

Any different dimension out of the standards above will be on request.

### XL461

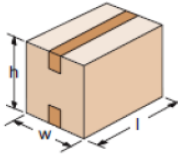

#### Standard

Taping Head K12/70	L	W	H
Min.	150	140	120*
Max.	∞	650	650

Taping Head K12/50	L	W	H
Min.	150	140	120*
Max.	∞	650	650

Any different dimension out of the standards above will be on request.

**Capacity Production :**  
up to 600 Bph

**Operating Pressure Range**      **Air Consumption :**  
from 5,5 bar - to 7 bar                      12 NI/cycle

Note. in case of box sizes over or under these range SIAT is able to produce special machines under request

## TAPING UNIT TYPE

K11/30

K12/30

K11/50

K12/50

K11/70

K12/70

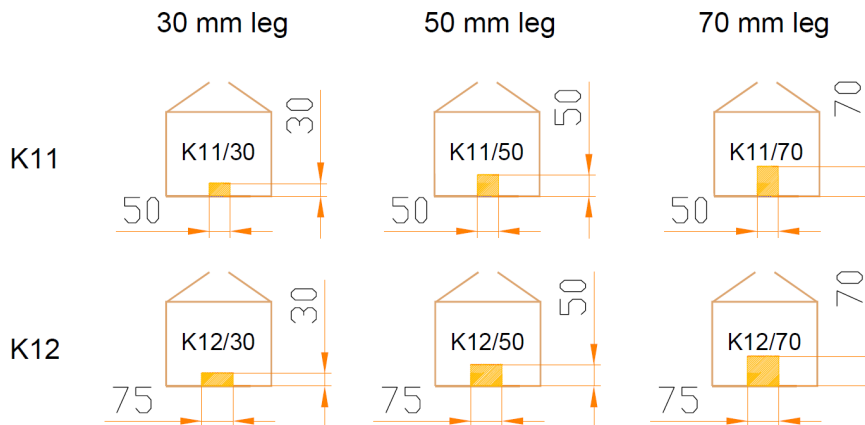

TAPING UNIT POSITION TOP + BOTTOM TOP ONLY + BOTTOM PLATE  
 MACHINE WORKING SIDE LEFT SIDE RIGHT SIDE

LEFT MACHINE

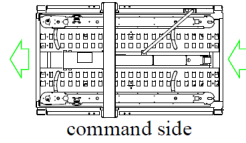

RIGHT MACHINE

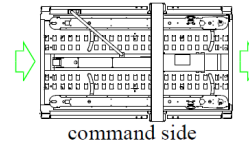

DOORS OPENING SIDE ONE SIDE  
 BOTH SIDES

WORKBENCH HEIGHT FROM 540 UP TO 800 mm

SPECIAL REQUEST FOR WORKBENCH HEIGHT

MACHINE ON WHEELS YES NOTE. IF YES +110 MM NEED TO BE ADDED  
 NO TO THE WORKBENCH HEIGHT

SAFETY GUARDS METALLIC GRIDS

POWER SUPPLY 380/415V 50HZ 3PH + PE

OTHER REQUEST , PLEASE SPECIFY

PNEUMATIC BRAND AVENTICS + FESTO ( standard )  
 FULL FESTO

## MACHINE COLORS

STANDARD COLORS: FRAME RAL 7016 - MOVING PARTS RAL 1021 - SAFETY GUARDS RAL 7040

INOX VERSION ( STAINLESS STEEL )

SPECIAL COLOR REQUEST:

FRAME

MOVING PARTS

METALLIC SAFETY GUARDS

## SPECIAL ENVIRONMENT CONDITIONS ( inside the company building )

HIGH ALTITUDE ( MORE THAN 1000 M A.S.L. ) please specify

HOT TEMPERATURE ( MORE THAN 40 °C ) please specify

LOW TEMPERATURE ( LESS THAN 5°C ) please specify

HIGH HUMIDITY ( MORE THAN 80% ) please specify

## ACCESSORIES

ENERGY SAVING DEVICE

( no need of PLC )

END TAPE DEVICE

( no need of PLC )

END/ BRAKE TAPE DEVICE

( PLC is needed )

PLC TYPE  
( if needed )

SIEMENS S7-1200 ( standard )

OMRON CP1

ALLEN BRADLEY MICROLOGIX

30 METERS /MINUTE BELT SPEED

(instead of 22 m/min )

## DOCUMENTATION LANGUAGE

ITALIAN

ENGLISH

GERMAN

FRENCH

SPANISH

OTHER, PLEASE SPECIFY

MACHINE LAYOUT ( Referral dimensions )

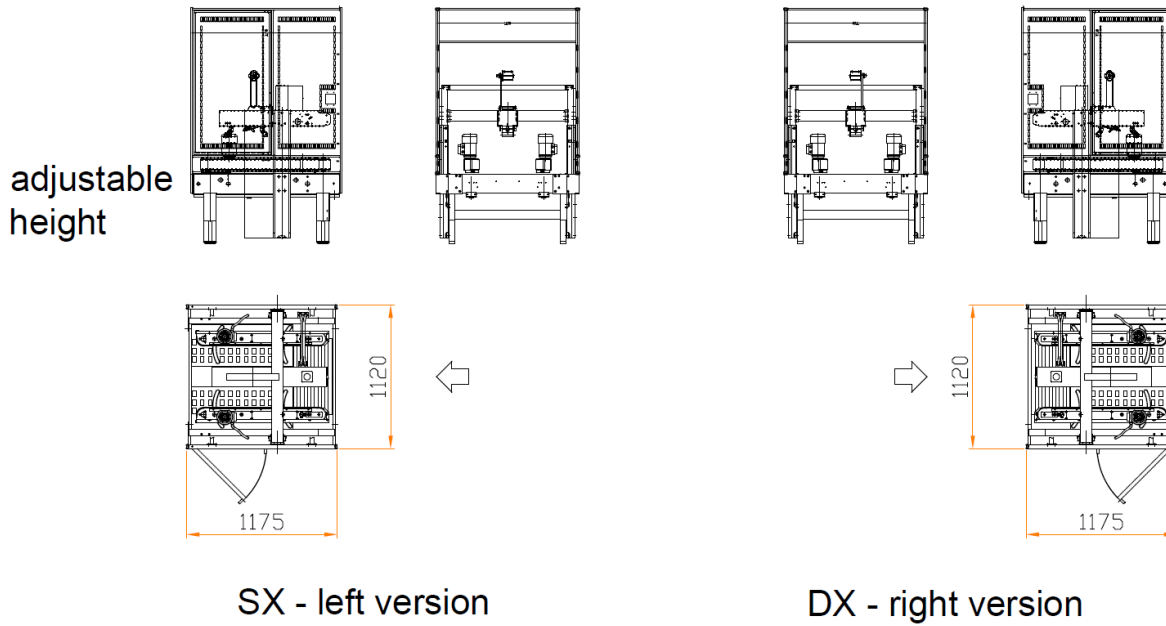

SIGNALS EXCHANGE ( only in case of XL46 PLC version )

**SIAT**  
CASE SEALER

- EMERGENCY
- MACHINE IN CYCLE



CUSTOMER  
OUTPUT LINE

SPECIAL REQUESTS ( if customer needs some other features )

**BOXES INFORMATION:** Note. standard weight range is 2- 30 kg, supposed for a product full box. Any other difference from these values should be evaluated by engineering department. In the last page the customer can check the general features required for the box.

	FEFCO TYPE	LENGTH (mm)	WIDTH (mm)	HEIGHT (mm)	WEIGHT (kg)	OUTPUT ( BPM )
BOX 1						
BOX 2						
BOX 3						
BOX 4						
BOX 5						
BOX 6						
BOX 7						
BOX 8						
BOX 9						
BOX 10						

WILL THE CUSTOMER SUPPLY BOXES TO BE TESTED?                      YES                      NO

IF YES PLEASE SEND SAMPLES TO:  
 SIAT S.P.A. via Puecher, 22 TURATE (CO) ITALY TO THE ATTENTION OF FLAVIO  
 PUGLIESE, AT LEAST TWO WEEKS BEFORE THE ESTIMATED DELIVERY DATE

IF YES, HOW MANY TYPES OF BOX DOES THE CUSTOMER WANT TO TEST?





5 TYPES - MAX 100 PIECES, TESTED FREE OF CHARGE



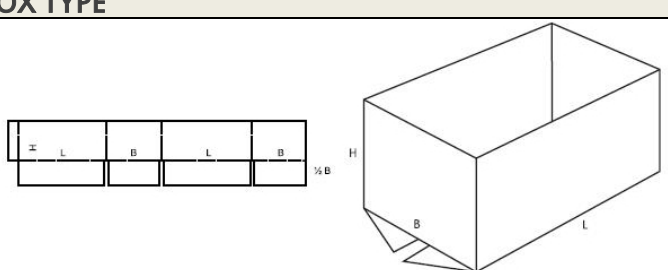
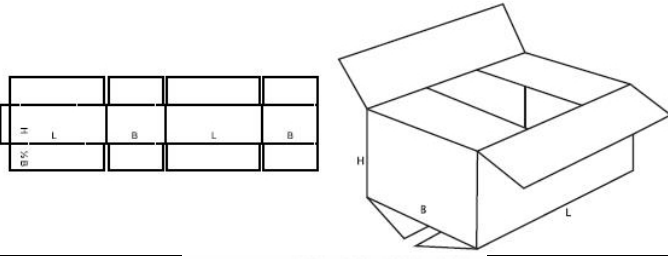

FROM 6 TO 10 TYPES - UNDER PAYMENT

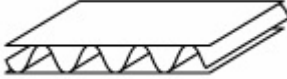
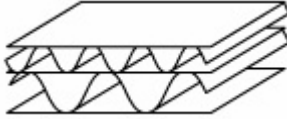
> 100 PIECES , UNDER PAYMENT

WILL THE CUSTOMER DO THE F.A.T. FOR THIS MACHINE?                      YES                      NO

WILL SIAT INSTALL THE MACHINE?  
 (under payment )                      YES                      NO

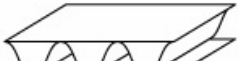
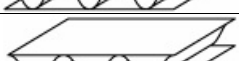
<i><b>CARTON TYPE</b></i>		
<b>FEFCO BOX TYPE</b>		
<b>BOX MODEL</b>	0200 M/A	
	0201 M/A	
<b>CARDBOARD TYPE LAYERS STYLE</b>	SINGLE FLUTE	
	TWO LAYERS + SINGLE FLUTE	
	THREE LAYERS + DOUBLE FLUTE	
	FOUR LAYERS + TRIPLE FLUTE	

<b>CARDBOARD TYPE FLUTE STYLE</b>	FLUTE "F"	
	FLUTE "E"	
	FLUTE "C"	
	FLUTE "B"	
	FLUTE "A"	

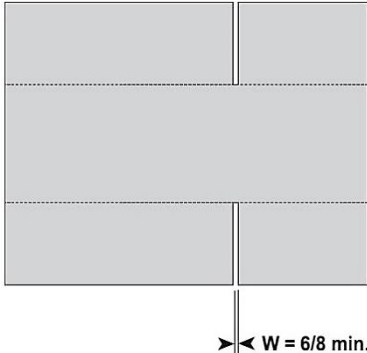
<b>FEFCO BOX TYPE</b>		
<b>MINIMUM BOXES REQUIREMENTS</b>	<ol style="list-style-type: none"> <li>1. GOOD TEXTURE OF CARTONS WITH SIDE FREE OF FOLDS</li> <li>2. CREASE LINE WELL MARKED. PREFERABLY DOUBLE.</li> <li>3. WHEN THE BOX IS CLOSED, FLAPS MUST NOT TOUCH THEMSELVES. MIN. 2 mm OF SPACE NEEDED.</li> <li>4. MIN. WIDTH OF CUTS: 6 – 8 mm (see picture)</li> <li>5. PLEASE ADVISE IN CASE OF USE OF SQUARE BOXES</li> <li>6. PLEASE ADVISE IN CASE OF SPECIAL PROCESSING OF CARDBOARD (ex. die-cutting)</li> <li>7. PLEASE ADVISE THE FEFCO BOX TYPE ACCORDING TO THE ABOVE CODIFICATION</li> </ol>	 <p style="text-align: right;">W = 6/8 min.</p>

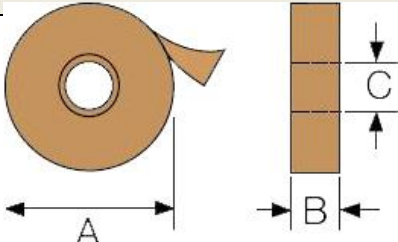
<b>TAPING UNIT PERFORMANCE</b>			
<b>TAPE REEL DIMENSIONS</b>	A	MAX. 410 mm	
	B	75 mm / 50 mm	
	C	76 mm	

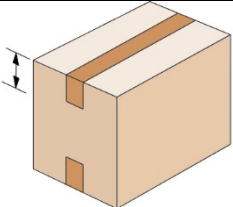
<b>TAPE LEG</b>			
<b>TAPE LEG DIMENSIONS</b>	K11R / K12R	70 mm	
	K11R / K12R	50 mm	
	K11/30 K12/30	30 mm	