



FREESBY 12

N. matricola • Serial number • Serienummer
N.d'identification • Matricula n.

**MACCHINA A PIATTAFORMA ROTANTE PER
L'AVVOLGIMENTO CON FILM PLASTICI
ESTENSIBILI**

**ROTATING PLATFORM MACHINE FOR PLASTIC
STRETCH FILM WRAPPING**

**MASCHINE MIT DREHPLATTFORM ZUR
UMWICKLUNG MIT KUNSTSTOFF-ST
RETCHFOLIEN**

**MACHINE À PLATE-FORME ROTATIVE POUR
L'EMBALLAGE PAR FILM PLASTIQUE EXTENSIBLE**

**MÁQUINA CON PLATAFORMA ROTATIVA PARA LA
ENVOLTURA CON PELÍCULAS PLÁSTICAS
EXTENSIBLES**

- ① CATALOGO RICAMBI
- Ⓒ SPARE PARTS LIST
- Ⓓ ERSATZTEILKATALOG
- Ⓕ CATALOGUE DES PIÉCES DÉTACHÉES
- Ⓔ CATALOGO RECAMBIOS



Basamento
Schabotte
Base

Base
Solle

Macchina
Maschine
Máquina

Machine
Machine

Tavola
Planche
Tabla

Table
Tafel

1/1

DW 1650

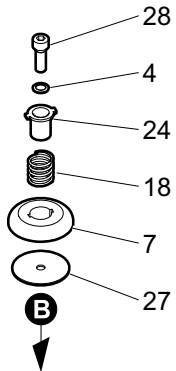

DW 1800

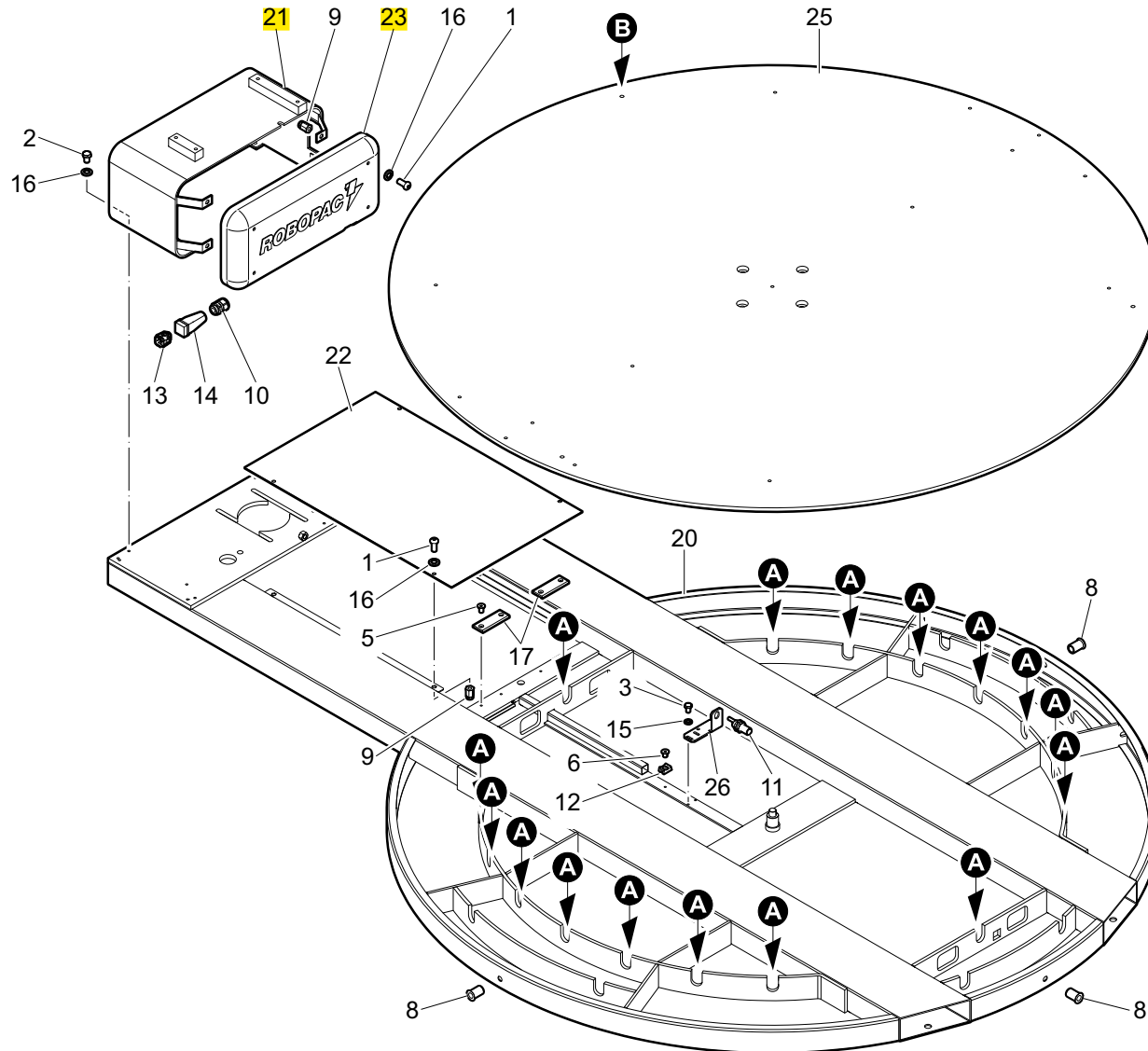
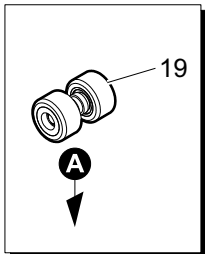
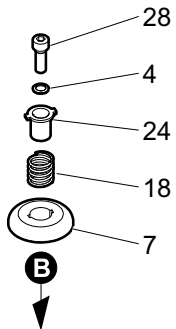

Variante rif. codice

1	000308271
2	000308181
3	000309113
4	000305165
5	000310121
6	000310138
7	6220300004
8	000301903
9	000317043
10	0001304627
11	0202300001
12	0001352458
13	0001353017
14	0001357351
15	00L0105504
16	00L0105507
17	0380602003
18	0381530023
19	2544300051
D:1650	20 3920300332
D:1800	20 3920300336
	21 4250300593
D:1650	22 4940300186
D:1800	22 4940300187
	23 5210300088
	24 5270300001
D:1650	25 5340300407
D:1800	25 5340300412
	26 5890301735
	27 4520300022
	28 000308364



Basamento
Schabotte
Base

Base
Solle

Macchina
Maschine
Máquina

Machine
Machine
Machine

Tavola
Planche
Tabla

Table
Tafel

1/1

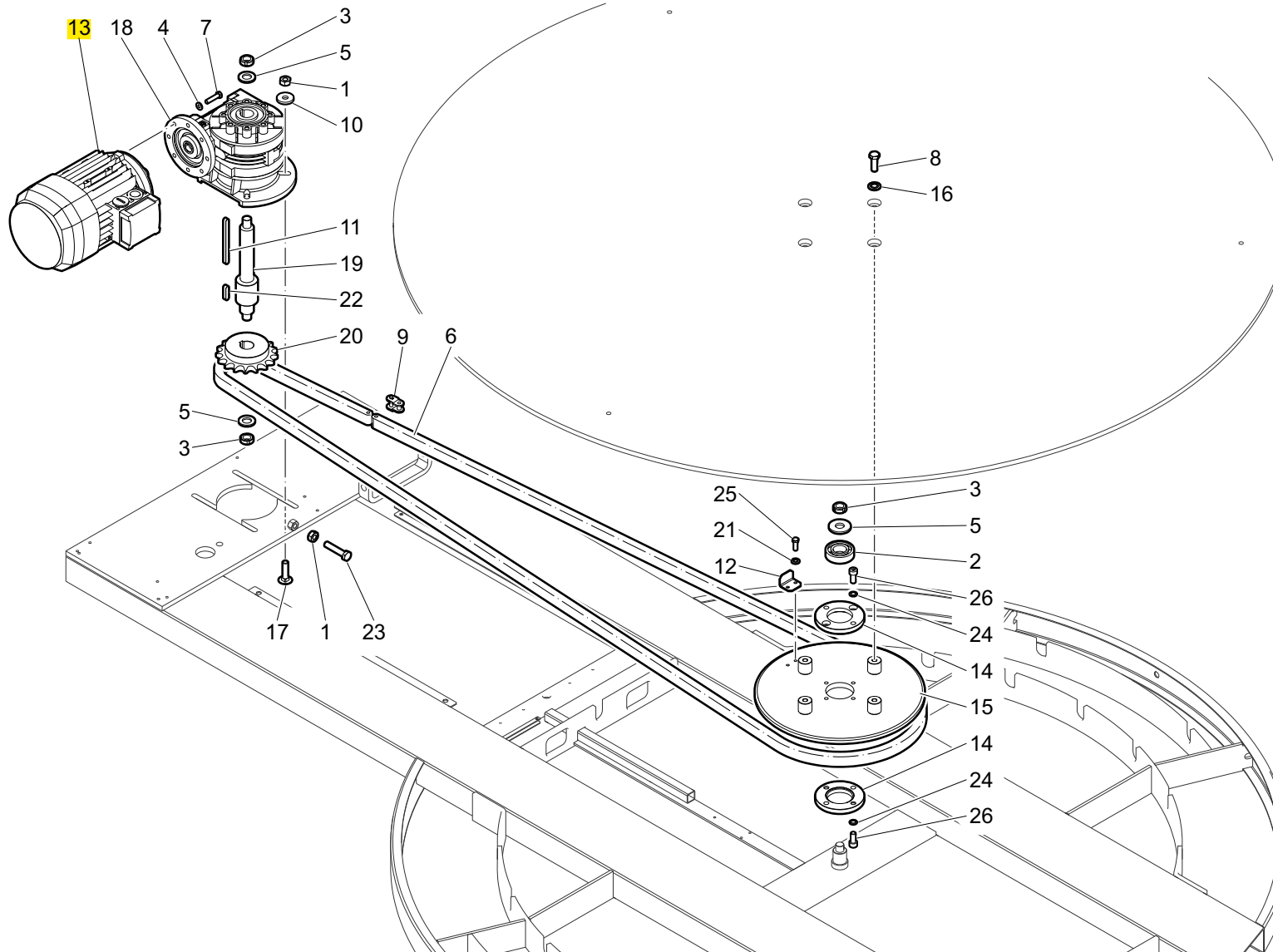

Variante rif. codice

1	0000301073
2	0000606110
3	0000301851
4	00L0105507
5	0000305490
6	0000606714
7	0000308275
8	00L0178108
9	0000602096
10	0000305305
11	0000645101
12	4940301233
13	0001340882
14	4730300097
15	4400300023
16	00L0105513
17	0001212044
18	2751300013
19	3740300620
20	5390300097
21	00L0105504
22	0000645033
23	0000308381
24	0000305257
25	0000309144
26	0000309245



Basamento (Convogliatore)
Schabotte (Förderband)
Base (Transportador)

Base (Carrier)
Solle (Convoyeur)

Macchina Maschine Máquina	Machine Machine Machine	DW-C	
Tavola Planche Tabla	Table Tafel		

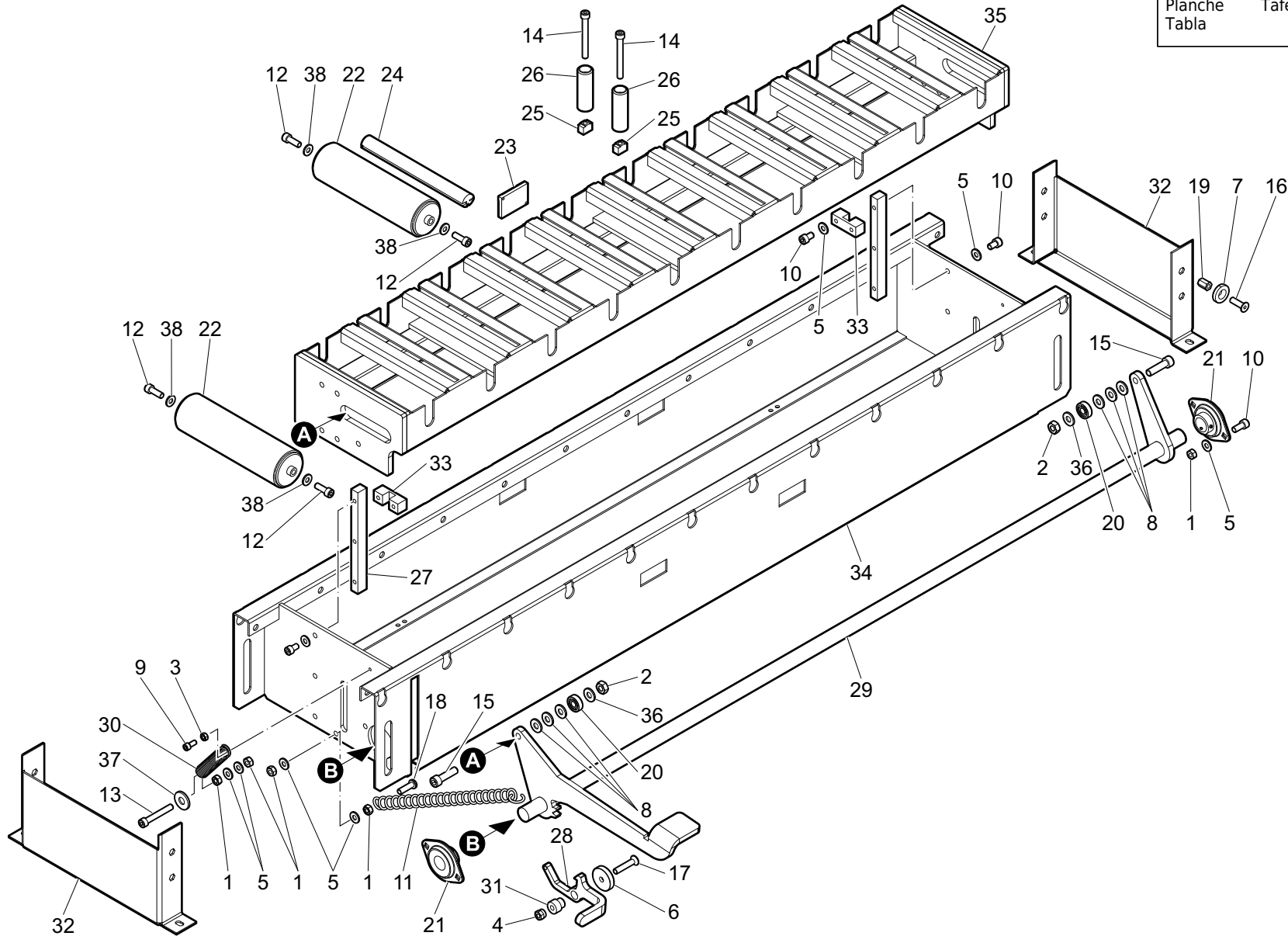

Variante rif.	codice
1	0000301072
2	0000301073
3	0000301181
4	0000301303
5	0000305242
6	0000305249
7	0000305253
8	0000305548
9	0000309200
10	0000309245
11	5120300020
12	0000309246
13	0000309253
14	0000309256
15	0000309306
16	0000310244
17	0000310246
18	0000315009
19	0000317044
20	0000606099
21	0000613257
22	0000641593
23	0001310195
24	2360300009
25	3980300131
26	4130300028
27	4820300649
28	5000300067
D:1650	29 5000300069
D:1800	29 5000300066
30	5120300037



Basamento (Convogliatore)
Schabotte (Förderband)
Base (Transportador)

Base (Carrier)
Solle (Convoyeur)

Macchina Maschine Máquina	Machine Machine Machine	DW-C	
Tavola Planche Tabla	Table Tafel		2/2

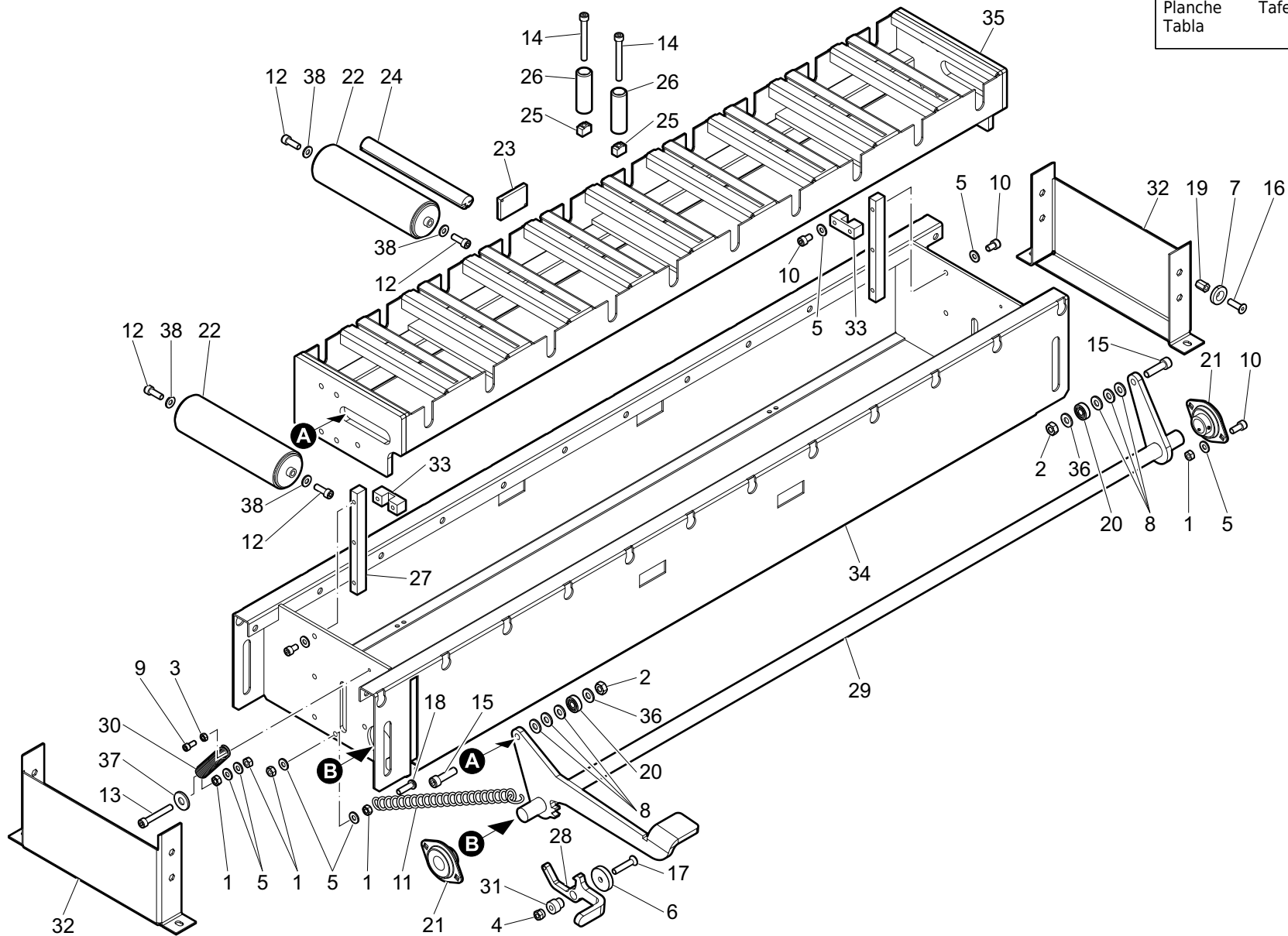

Variante rif.	codice
31	5270300743
32	5360300072
33	5720300004
D:1650 34	6040300555
D:1800 34	6040300553
D:1650 35	6040300556
D:1800 35	6040300554
36	0000305300
D:1800 37	0000305256
38	0000305263

PRESSORE "CILINDRO SENZA STELO"

"NO ROD CYLINDER" PRESSER - NIERDEHALTER "ZYLINDER OHNE SCHAFT"
 PRESSEUR "CYLINDRE SANS TIGE" - PRENSADOR "CILINDRO SIN VÁSTAGO"

IDM - 24156001000

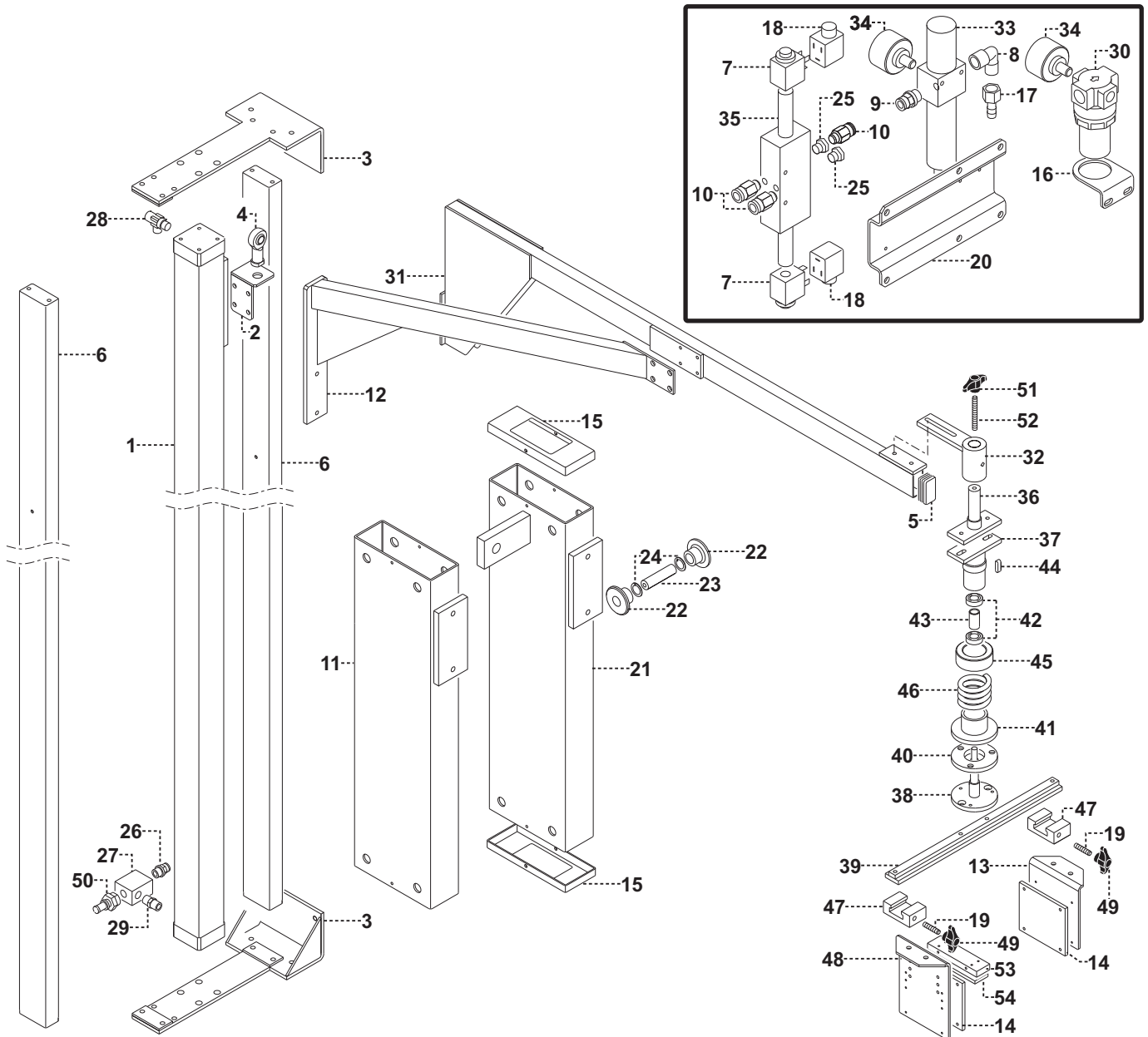

2415600

N. Cod.		N. Cod.		N. Cod.		N. Cod.	
H=2400	1 0001510366	16	0001502890	35	0001510052	54	6010300023
H=2800	1 0001510711	17	0001901085	36	5890300318		
H=3100	1 0001511363	18	0001353240	37	0580794260		
	2 5740300155	19	0380581750	38	0580794650		
	3 5340300163	20	5890300225	39	0580794730		
	4 0000629056	21	4220300008	40	0381370020		
	5 0000640702	22	2544300001	41	0380150570		
H=2400	6 4820300003	23	5270300009	42	0000606045		
H=2800	6 4820300066	24	0000305086	43	0380300830		
H=3100	6 4820300117	25	0001908105	44	0000645047		
	7 0001502496	26	0001904182	45	0380400010		
	8 0001906005	27	0001502024	46	0381530020		
	9 0001904182	28	0001508834	47	0380460880		
	10 0001904169	29	0001907012	48	5890301622		
	11 4220300039	30	0001508143	49	0000619973		
	12 5890300584	31	3800300049	50	0001508091		
	13 5890301621	32	5890300197	51	0000619974		
	14 6010300022	33	0001500957	52	0000304252		
	15 5950300008	34	0001505030	53	5890301632		

