



WRAPPY

9S/9A

N. matricola • Serial number • Seriennummer
N.d'identification • Matricula n.

FASCIATRICE AD ANELLO ROTANTE
ROTATING RING BANDING MACHINE
VERPACKUNGSMASCHINE MIT DREHRING
MACHINE A CERCLER A BAGUE TOURNANTE
ENROLLADORA CON ANILLO ROTANTE

- ① CATALOGO RICAMBI
- Ⓒ SPARE PARTS LIST
- Ⓓ ERSATZTEILKATALOG
- Ⓕ CATALOGUE DES PIECES DETACHEES
- Ⓔ CATALOGO RECAMBIOS

3710309472

Ed.: 01/2012





I	Come consultare il catalogo delle parti di ricambio
GB	How to consult the spare parts catalogue
D	Benutzung des Ersatzteilkatalogs
F	Comment consulter le catalogue des pièces détachées
E	Cómo consultar el catálogo de las piezas de repuesto

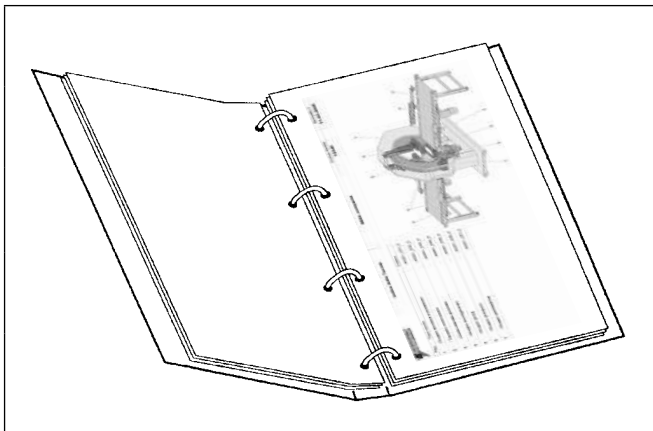

- I** Tramite l'indice figurativo, posto all'inizio del catalogo, si individua il numero di tavola relativa alla parte della macchina che interessa.
- GB** Use the illustration index at the beginning of the catalogue to identify the number of the table of the concerned machine part.
- D** Mittels des Bildindex am Anfang des Katalogs kann die Nummer der Tafel herausgefunden werden, die zu dem gesuchten Maschinenteil gehört.
- F** Grâce à l'index figuratif, placé au début du catalogue, on identifie le numéro de planche correspondant à la pièce de la machine intéressée.
- E** Con el índice figurativo, colocado al comienzo del catálogo, se identifica el número de tabla referida a la pieza de la máquina que interesa.

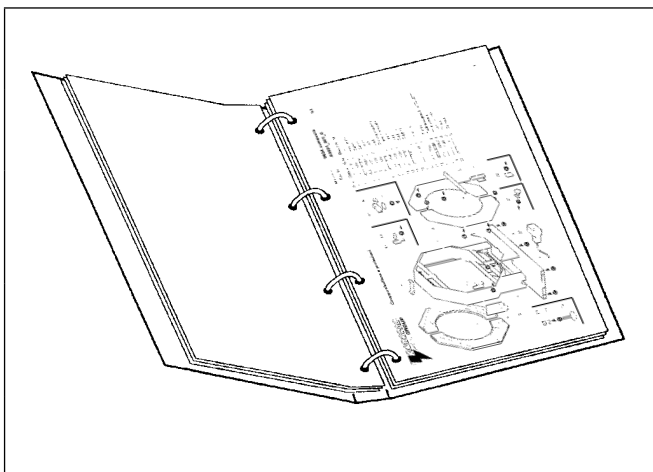

- I** Su ogni tavola, ad ogni particolare è attribuito un numero di riferimento. Nella tabella, ad ogni riferimento corrispondono tutti i dati necessari per l'ordinazione.
- GB** A reference number is assigned to each part in each table. Each reference in the table includes all the information required for ordering.
- D** Auf jeder Tafel ist jedem Einzelposten eine Referenznummer zugewiesen. In der Tabelle findet man zu jeder Bezugsnummer entsprechend alle zur Bestellung nötigen Daten.
- D** Sur chaque planche, à chaque pièce est attribuée un numéro de référence. Sur la planche, à chaque référence correspondent toutes les données nécessaires pour la commande.
- E** En cada tabla, a cada pieza se le atribuye un número de referencia. En la tabla, a cada referencia le corresponden todos los datos necesarios para el pedido.

I	NORME PER LE ORDINAZIONI
GB	ORDERING INSTRUCTIONS
D	NORMEN FÜR DIE BESTELLUNGEN
F	NORMES POUR LES COMMANDES
E	NORMAS PARA LOS PEDIDOS

Targhetta di identificazione macchina
Machine identification plate

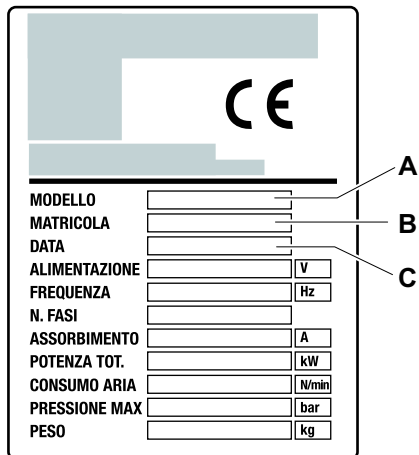

The form includes the following fields:

- MODELLO
- MATRICOLA
- DATA
- ALIMENTAZIONE V
- FREQUENZA Hz
- N. FASI
- ASSORBIMENTO A
- POTENZA TOT. kW
- CONSUMO ARIA N/min
- PRESSIONE MAX bar
- PESO kg

Labels A, B, and C point to the top section, the MATRICOLA field, and the ALIMENTAZIONE field respectively.

- I** Le ordinazioni delle parti di ricambio devono essere corredate dalle seguenti indicazioni:
1. Modello macchina (**A**)
 2. Matricola (**B**)
 3. Anno di produzione (**C**)
 4. Numero della tavola
 5. Numero di riferimento del particolare
 6. Numero di codice del particolare
 7. Quantità richiesta
 8. Modo di spedizione

- GB** Spare part orders must include the following information:
1. Machine model (**A**)
 2. Serial number (**B**)
 3. Year of manufacture (**C**)
 4. Table number
 5. Part reference number
 6. Part code number
 7. Required quantity
 8. Delivery method

 **Informazioni**
Per i componenti colorati specificare il colore desiderato.
Nota: Effettuare la richiesta dei ricambi compilando l'apposita scheda in ogni sua parte.

 **Information**
For coloured components, indicated the required colour
Note: Fully complete the specific form when ordering spare parts.

Identifikationsplakette der Maschine
Plaquette d'identification machine
Placa de identificación de la máquina

	
MODELLO	<input type="text"/>
MATRICOLA	<input type="text"/>
DATA	<input type="text"/>
ALIMENTAZIONE	<input type="text"/> V
FREQUENZA	<input type="text"/> Hz
N. FASI	<input type="text"/>
ASSORBIMENTO	<input type="text"/> A
POTENZA TOT.	<input type="text"/> kW
CONSUMO ARIA	<input type="text"/> N/min
PRESSIONE MAX	<input type="text"/> bar
PESO	<input type="text"/> kg

D Die Bestellungen von Ersatzteilen müssen nach folgenden Angaben erstellt werden.

1. Maschinenmodell (A)
2. Seriennummer(B)
3. Baujahr (C)
4. Tafelnummer
5. Referenznummer des Einzelteils
6. Codenummer des Einzelteils
7. Gewünschte Menge
8. Versandart

F Les commandes de pièces détachées doivent être accompagnées des indications suivantes:

1. Modèle machine (A)
2. Matricule (B)
3. Année de production (C)
4. Numéro de la planche
5. Numéro de référence de la pièce
6. Numéro de code de la pièce
7. Quantité requise
8. Moyen d'expédition

E Los pedidos de las piezas de repuesto deben ir acompañados de las siguientes indicaciones:

1. Modelo máquina (A)
2. Número de matrícula(B)
3. Año de producción(C)
4. Número de la tabla
5. Número de referencia de la pieza
6. Número de código de la pieza
7. Cantidad solicitada
8. Modo de envío



Informationen

Bei farbigen Komponenten bitte die gewünschte Farbe angeben.

Anmerkung: Die Anforderung der Ersatzteile durch Ausfüllen des entsprechenden Blattes in jedem seiner Teile ausführen.



Informations

Pour les composants colorés spécifier la couleur souhaitée.

Note: Effectuer la demande de pièces détachées en compilant entièrement la fiche correspondante.



Información

Para los componentes coloreados especificar el color deseado

Nota: Efectuar el pedido de repuestos completando toda la ficha.



Rif.	Tavola Planche Tafel Tabla	Titolo tavola Titre planche Título tabla	Table heading Titel der Tafel	
1	A1208_001	Gruppo struttura e protezioni Gruppe Aufbau und Schutzvorrichtungen Grupo estructura y protecciones 9S	Machine body and protections Groupe structure et protections	pag.: 13
2	A1208_002	Gruppo struttura e protezioni Gruppe Aufbau und Schutzvorrichtungen Grupo estructura y protecciones 9A	Machine body and protections Groupe structure et protections	pag.: 14
3	A1208_003	Gruppo struttura e protezioni Gruppe Aufbau und Schutzvorrichtungen Grupo estructura y protecciones 9A	Machine body and protections Groupe structure et protections	pag.: 15
4	A1102_002	Quadro elettrico Elektr. tafel Quadro electrico BOB. 125	Electrical board Tableau électrique	pag.: 16
5	A1106_015	Quadro elettrico Elektr. tafel Quadro electrico BOB. 250	Electrical board Tableau électrique	pag.: 17
6	A1106_003	Gruppo alimentazione a nastro Bandzuführungsgruppe Grupo alimentación de cinta L:600 W:500	Belt infeed unit Groupe alimentation à bande	pag.: 18
7	A1106_004 OPT	Gruppo alimentazione a nastro Bandzuführungsgruppe Grupo alimentación de cinta L:1500	Belt infeed unit Groupe alimentation à bande	pag.: 19
8	A1106_013 OPT	Gruppo alimentazione a nastro Bandzuführungsgruppe Grupo alimentación de cinta L:850 W:815	Belt infeed unit Groupe alimentation à bande	pag.: 20
9	A1106_014 OPT	Gruppo alimentazione a nastro Bandzuführungsgruppe Grupo alimentación de cinta L:1500 W:815	Belt infeed unit Groupe alimentation à bande	pag.: 21

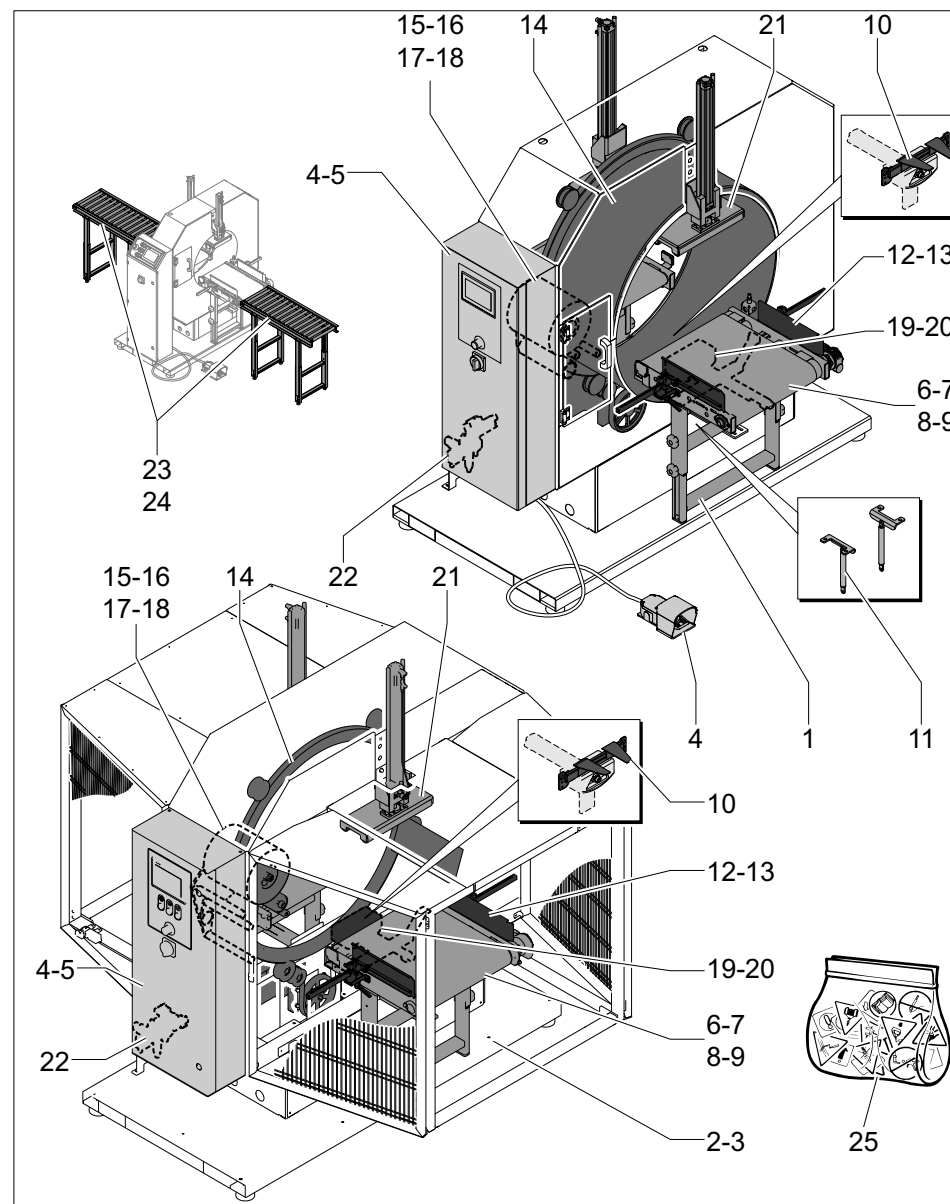

Rif.	Tavola Planche Tafel	Titolo tavola Titre planche Título tabla	Table heading Titel der Tafel	
10	A1106_012 OPT	Gruppo ponte Bruecke-gruppe Grupo puente BOB. 125/250 W:500/815	Bridge unit Groupe pont	pag.: 22
11	A1106_011 OPT	Gruppo di sollevamento (Convogliatore) Hebegruppe (Förderband) Grupo de elevación (Transportador)	Lifting unit (Carrier) Groupe de soulevement (Convoyeur)	pag.: 23
12	A1106_005 OPT	Gruppo guida laterale Gruppe Seitenführungen Grupo guía lateral L: 600	Side guide unit Groupe guide latéral	pag.: 24
13	A1106_006 OPT	Gruppo guida laterale Gruppe Seitenführungen Grupo guía lateral L: 1500	Side guide unit Groupe guide latéral	pag.: 25
14	A1104_006	Gruppo avvolgimento Umwickelgruppe Grupo envoltura	Wrapping unit Groupe banderolage	pag.: 26
15	A1104_009	Gruppo portabobina Folienrollengruppe Grupo portabobina BOB. 125	Spool carriage Groupe porte-bobine	pag.: 27
16	A1105_010	Gruppo portabobina Folienrollengruppe Grupo portabobina BOB. 250	Spool carriage Groupe porte-bobine	pag.: 28
17	A1104_010 OPT	Gruppo portabobina + Rullo ballerino Folienrollengruppe + Schwingen roll Grupo portabobina + Rodillo oscilante BOB. 125	Spool carriage + Swinging roll Gr. porte-bobine + Rouleau oscillant	pag.: 29
18	A1105_011 OPT	Gruppo portabobina + Rullo ballerino Folienrollengruppe + Schwingen roll Grupo portabobina + Rodillo oscilante BOB. 250	Spool carriage + Swinging roll Gr. porte-bobine + Rouleau oscillant	pag.: 30

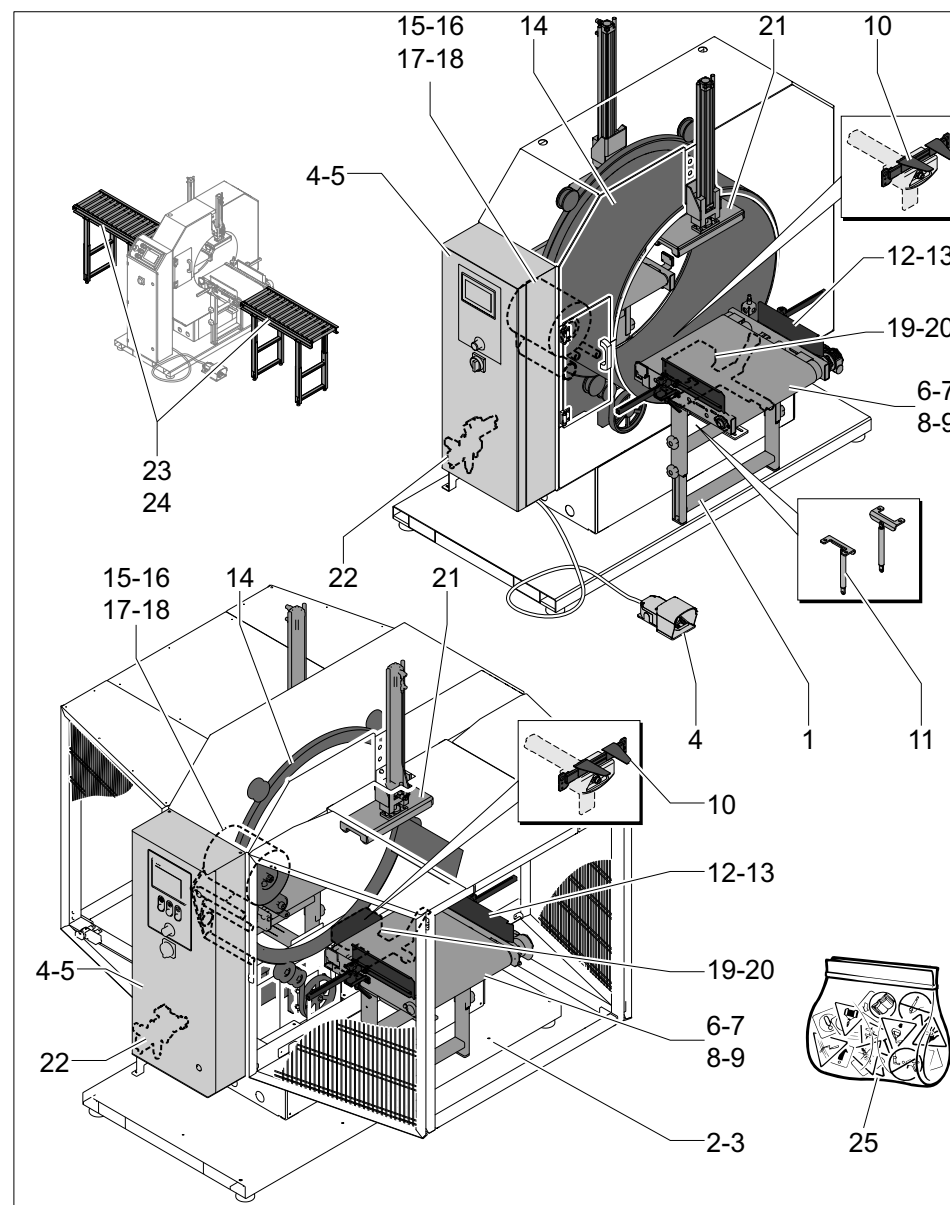

Rif.	Tavola Planche Tafel Tabla	Titolo tavola Titre planche Título tabla	Table heading Titel der Tafel
19	A1106_007	Gruppo pinza/taglio Spannzangen/schneide-einheit Grupo pinza/corte BOB . 125/250	Pliers/cutting unit Groupe pince/deco upage pag.: 32
20	A1106_008	Gruppo pinza/taglio Spannzangen/schneide-einheit Grupo pinza/corte W:815 BOB.125/250	Pliers/cutting unit Groupe pince/deco upage pag.: 33
21	A1106_009	Gruppo pressore Niederhaltergruppe Grupo presor L:400-600 BOB.125-250	Pressure platen unit Groupe presseur pag.: 34
22	A1208_004	Impianto pneumatico Pneumatische anlage Instalacion neumatica	Pneumatic system Circuit pneumatique pag.: 35
23	A1104_014 OPT	Gruppo convogliatore folle Einheit förderer Grupo transportador L:1000W:650	Idle conveyor unit Groupe convoyeur fou pag.: 36
24	A1104_015 OPT	Gruppo convogliatore folle Einheit förderer Grupo transportador L:2000W:650	Idle conveyor unit Groupe convoyeur fou pag.: 37
25	A1208_005	Kit targhette Schild Kit placas	Plate kit Kit de plaquettes pag.: 38

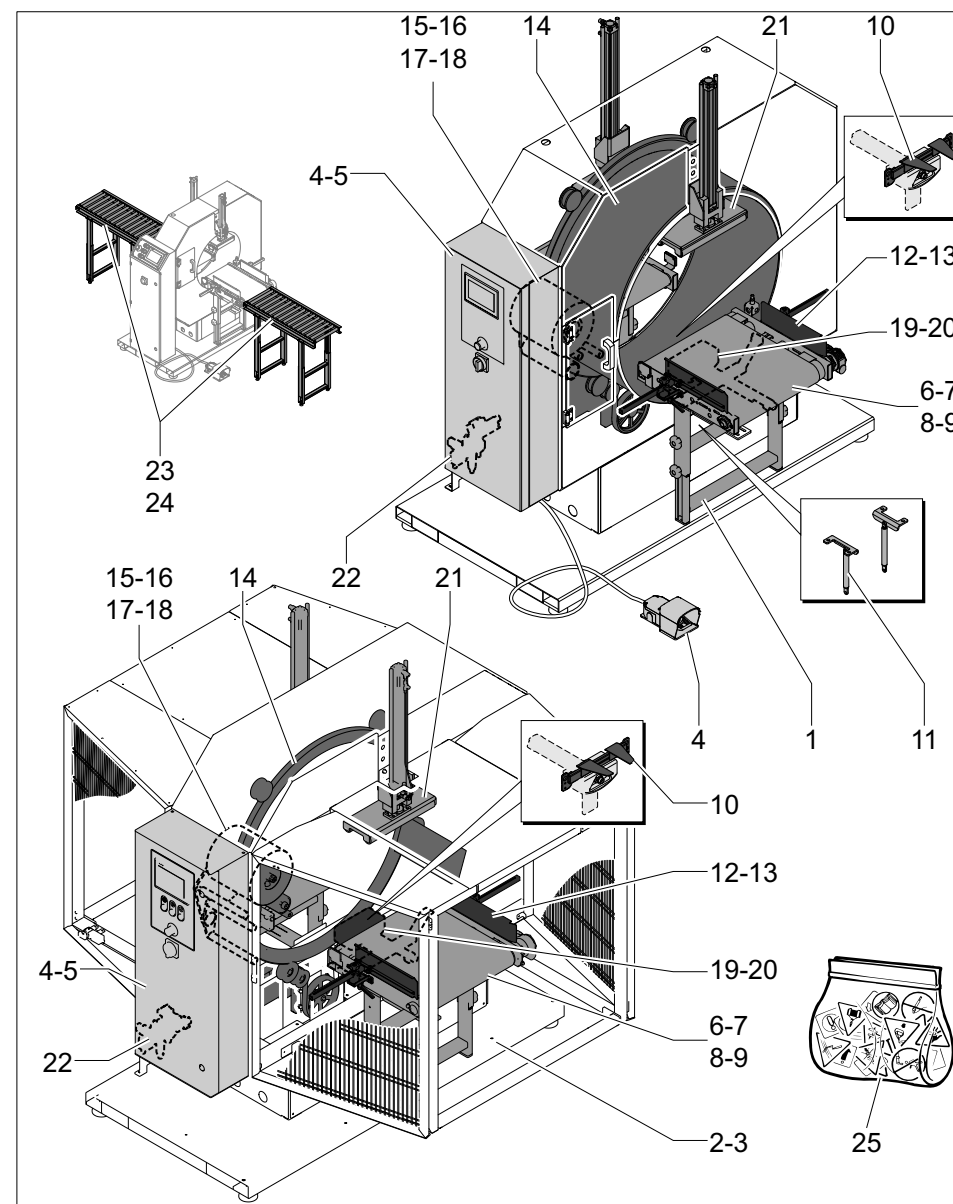





Gruppo struttura e protezioni
 Gruppe Aufbau und Schutzvorrichtungen
 Grupo estructura y protecciones

Machine body and protections
 Groupe structure et protections

Macchina
 Maschine
 Máquina

WRAPPY 9S/9A

9S

Tavola
 Planche
 Tabla

Table
 Tafel

A1208_001

1/1

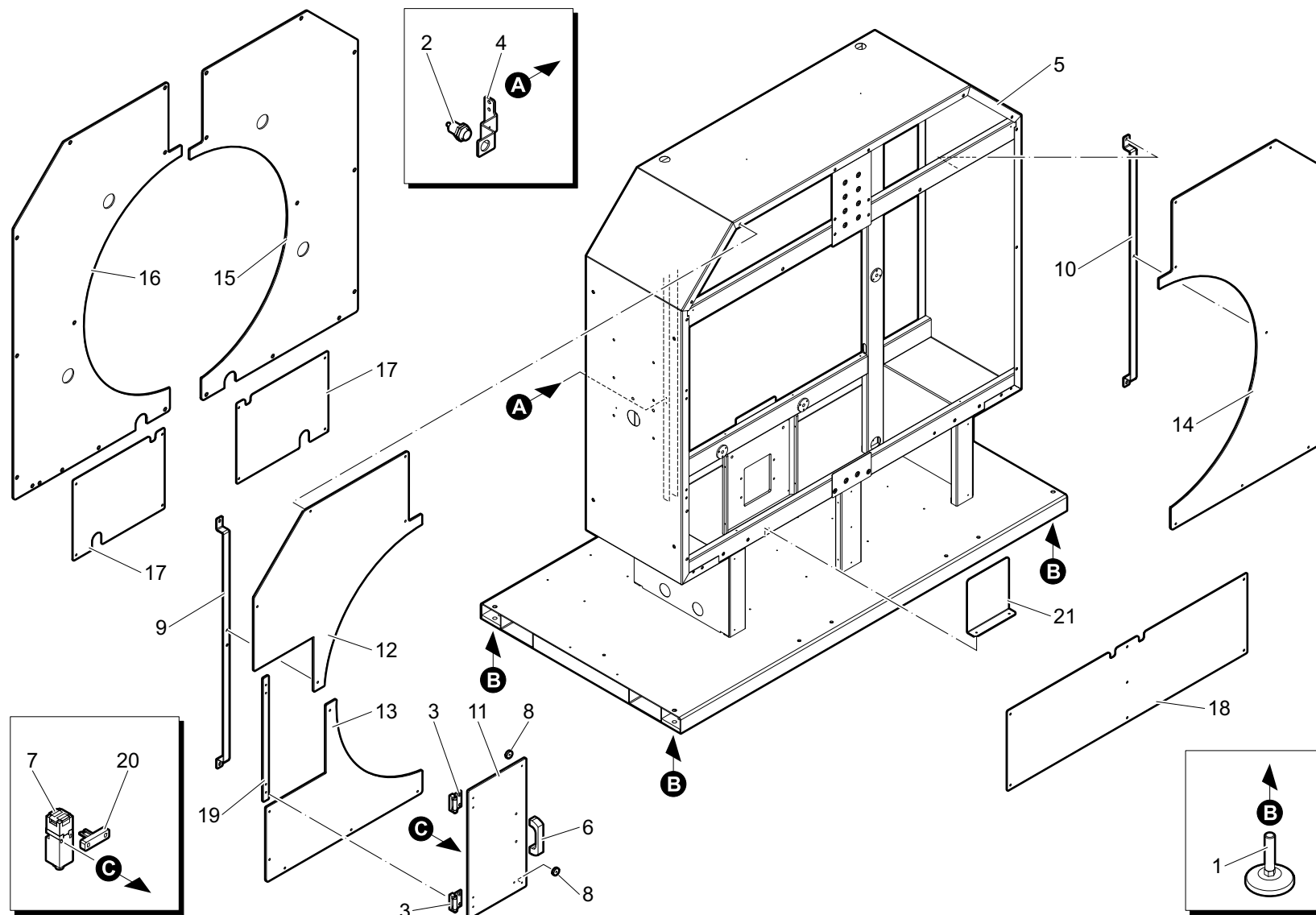

Variante rif. codice

1	0000636584
2	0001300299
3	0001310970
4	5740300598
5	7210300043
6	0000619691
7	0001300998
8	0001310969
9	3830300099
10	3830300101
11	4250301159
12	4250301279
13	4250301280
14	4250301281
15	4250301282
16	4250301283
17	4940301032
18	4940301033
19	5030300047
20	0001309918
21	5560300379



Gruppo struttura e protezioni
 Gruppe Aufbau und Schutzvorrichtungen
 Grupo estructura y protecciones

Machine body and protections
 Groupe structure et protections

Macchina
 Maschine
 Máquina

WRAPPY 9S/9A

9A

Tavola
 Planche
 Tabla

Table
 Tafel

A1208_002

1/1

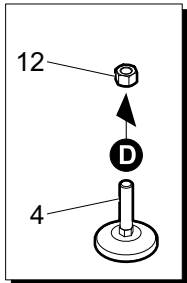
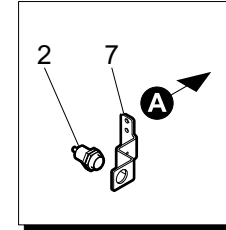
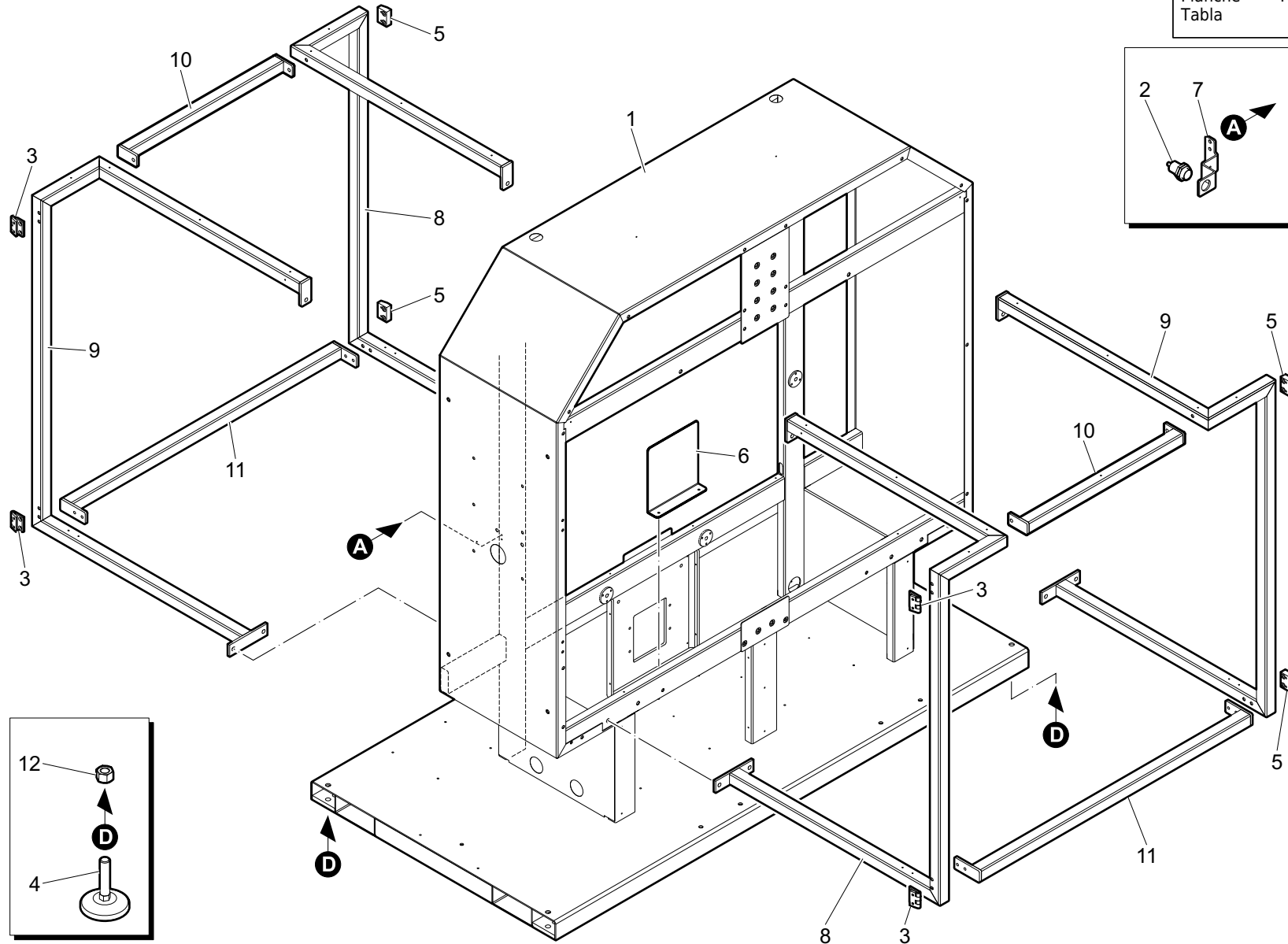

Variante rif.	codice
1	7210300043
2	0001300299
3	0580510015
4	0000636584
5	3980300123
6	5560300379
7	5740300598
8	6040300531
9	6040300532
10	6130300200
11	6130300207
12	0000301543



Gruppo struttura e protezioni
 Gruppe Aufbau und Schutzvorrichtungen
 Grupo estructura y protecciones

Machine body and protections
 Groupe structure et protections

Macchina
 Maschine
 Máquina

Machine
 Machine
 Machine

WRAPPY 9S/9A

9A

Tavola
 Planche
 Tabla

Table
 Tafel

A1208_003

1/1

Variante rif. codice

1	5560300352
2	00L0031656
3	4940301053
4	5560300374
5	5560300384
6	5830300568
7	4250301221
8	4250301222
9	4940301032
10	4940301033
11	4940301088
12	5830300548
13	0001300998
14	00L0035391

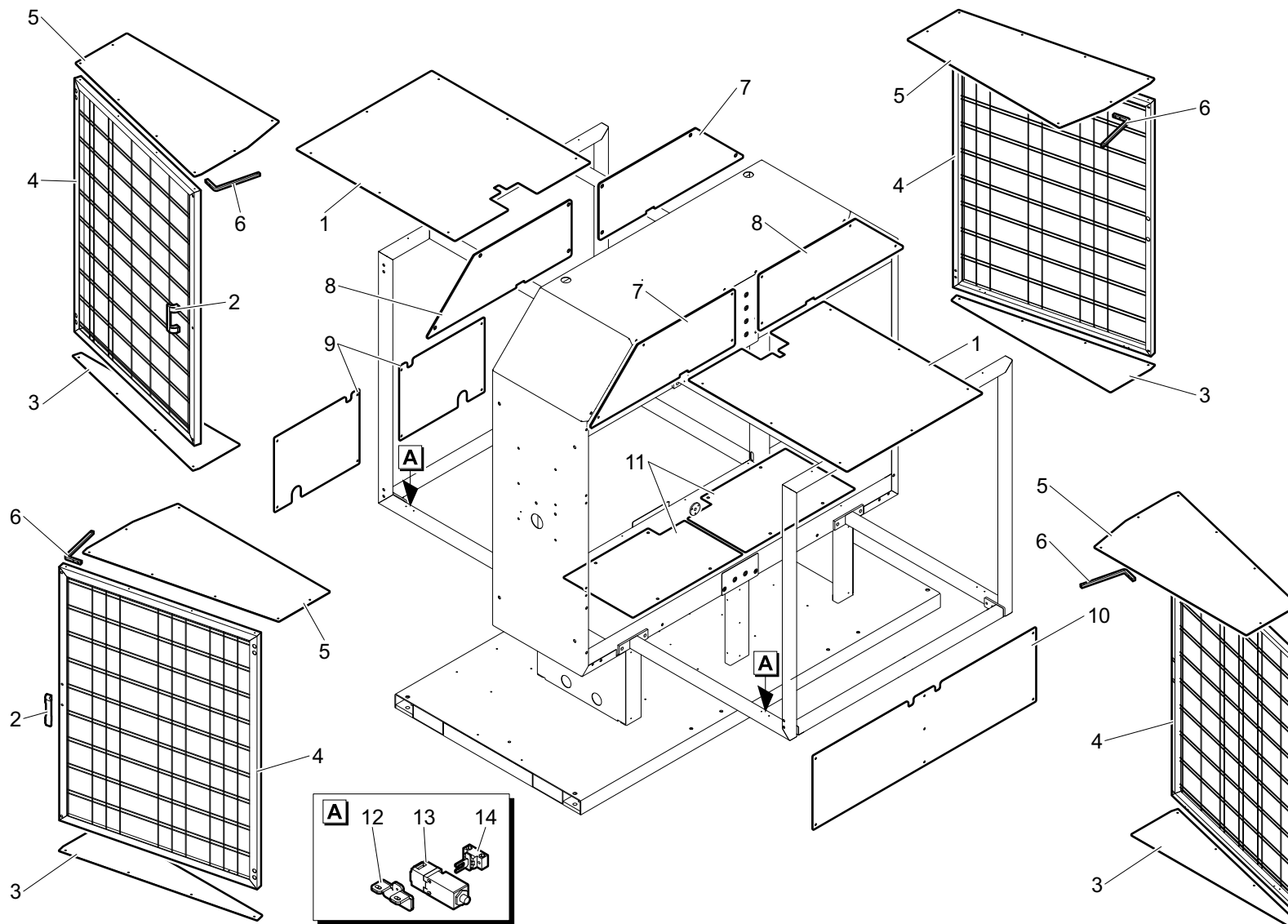



Quadro elettrico Elektr. tafel Quadro electrico	Electrical board Tableau électrique	Macchina Maschine Máquina	Machine Machine	WRAPPY 9S/9A	
BOB.125		Tavola Planche Tabla	Table Tafel	A1102_002	1/1

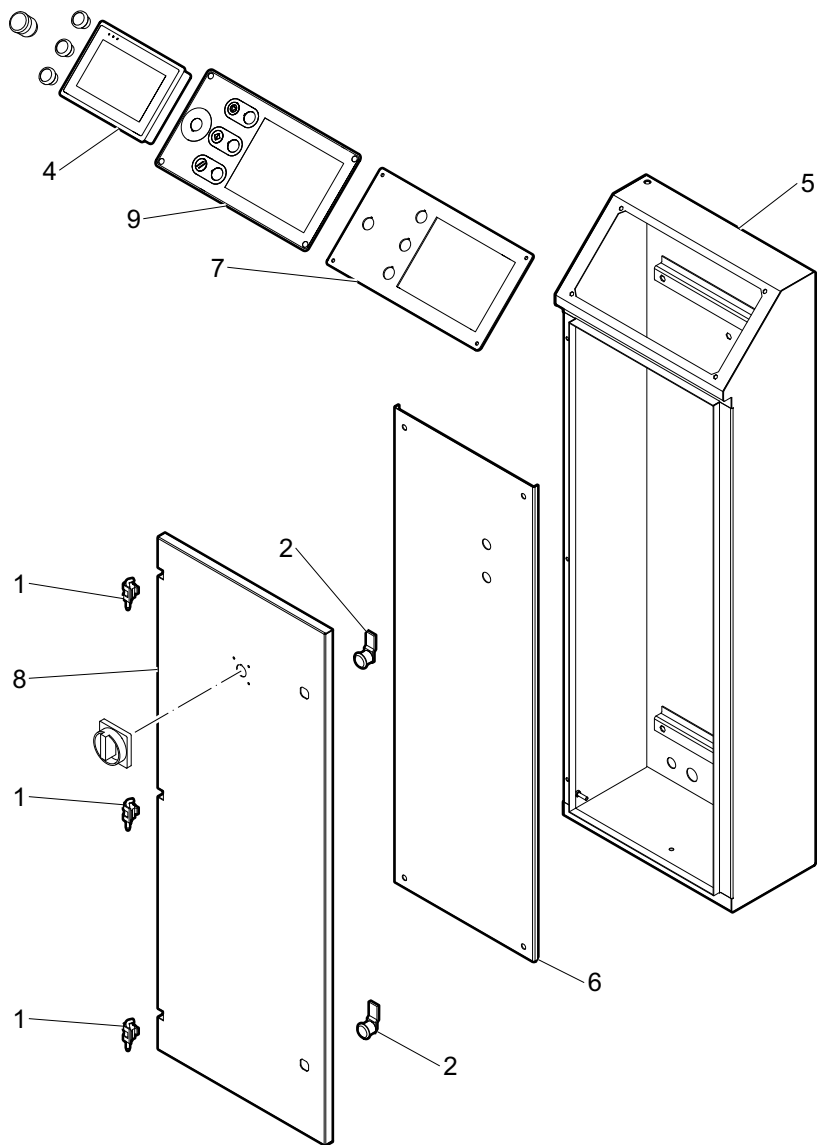

Variante rif. codice

1	000626478
2	000626479
3	0622300001
4	1400300002
5	4280300153
6	4940300821
7	5210300293
8	5210300294
9	5920300684

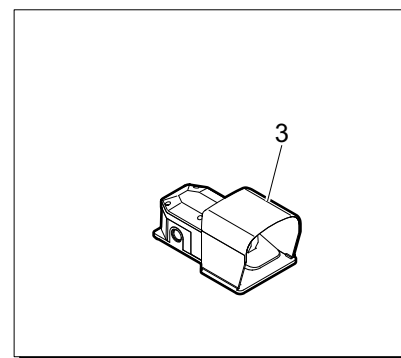



Quadro elettrico Elektr. tafel Quadro electrico	Electrical board Tableau électrique	Macchina Maschine Máquina	Machine Machine	WRAPPY 9S/9A	
BOB.250		Tavola Planche Tabla	Table Tafel	A1106_015	1/1

Variante rif. codice

1	5920300668
2	0000626478
3	5210300295
4	0000626647
5	4940300821
6	4280300154
7	0622300001

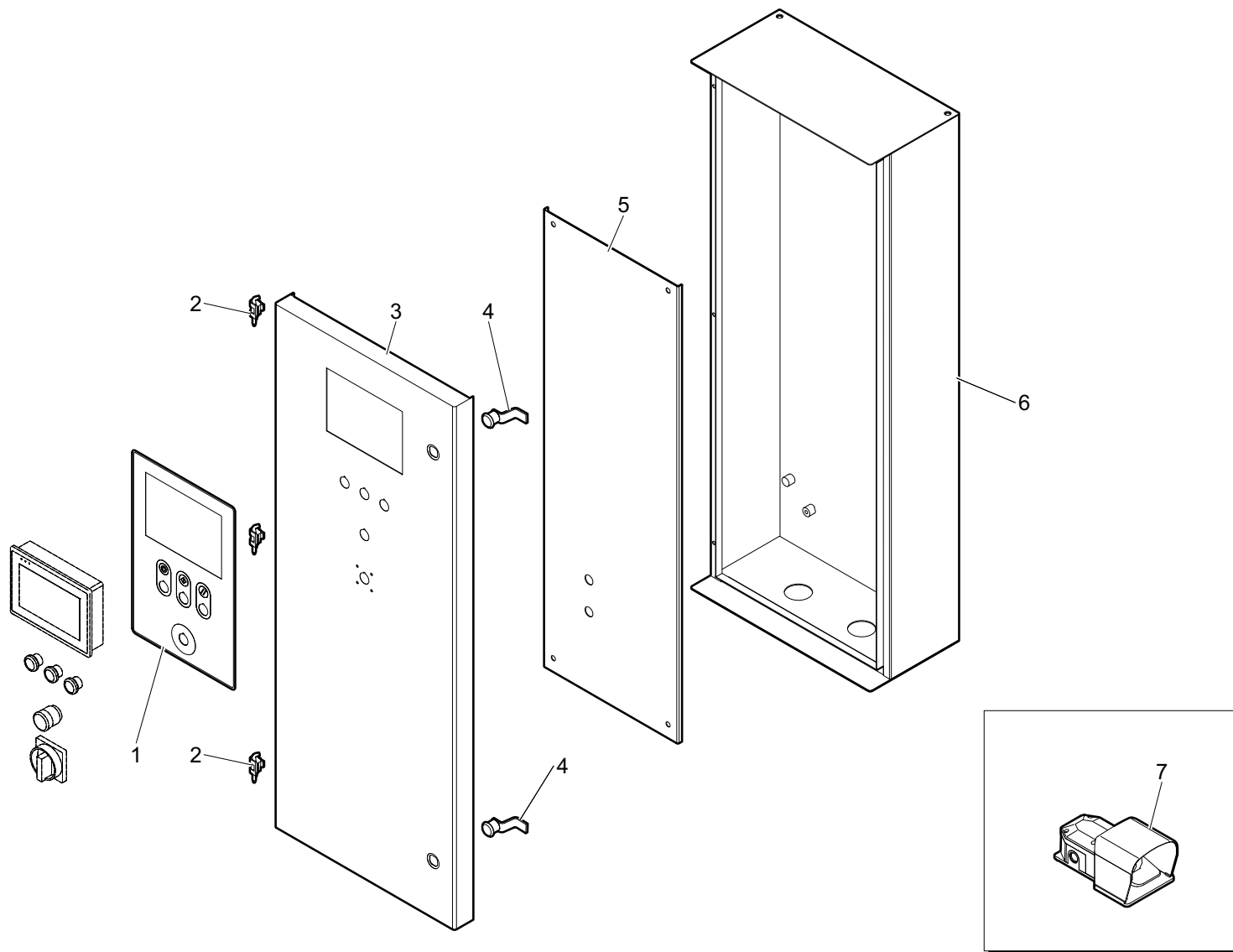



Gruppo alimentazione a nastro
Bandzuführungsgruppe
Grupo alimentación de cinta

Belt infeed unit
Groupe alimentation à bande

Macchina
Maschine
Máquina

Machine
Machine
Machine

WRAPPY 9S/9A

L:600 W:500

Tavola
Planche
Tabla

Table
Tafel

A1106_003

1/1

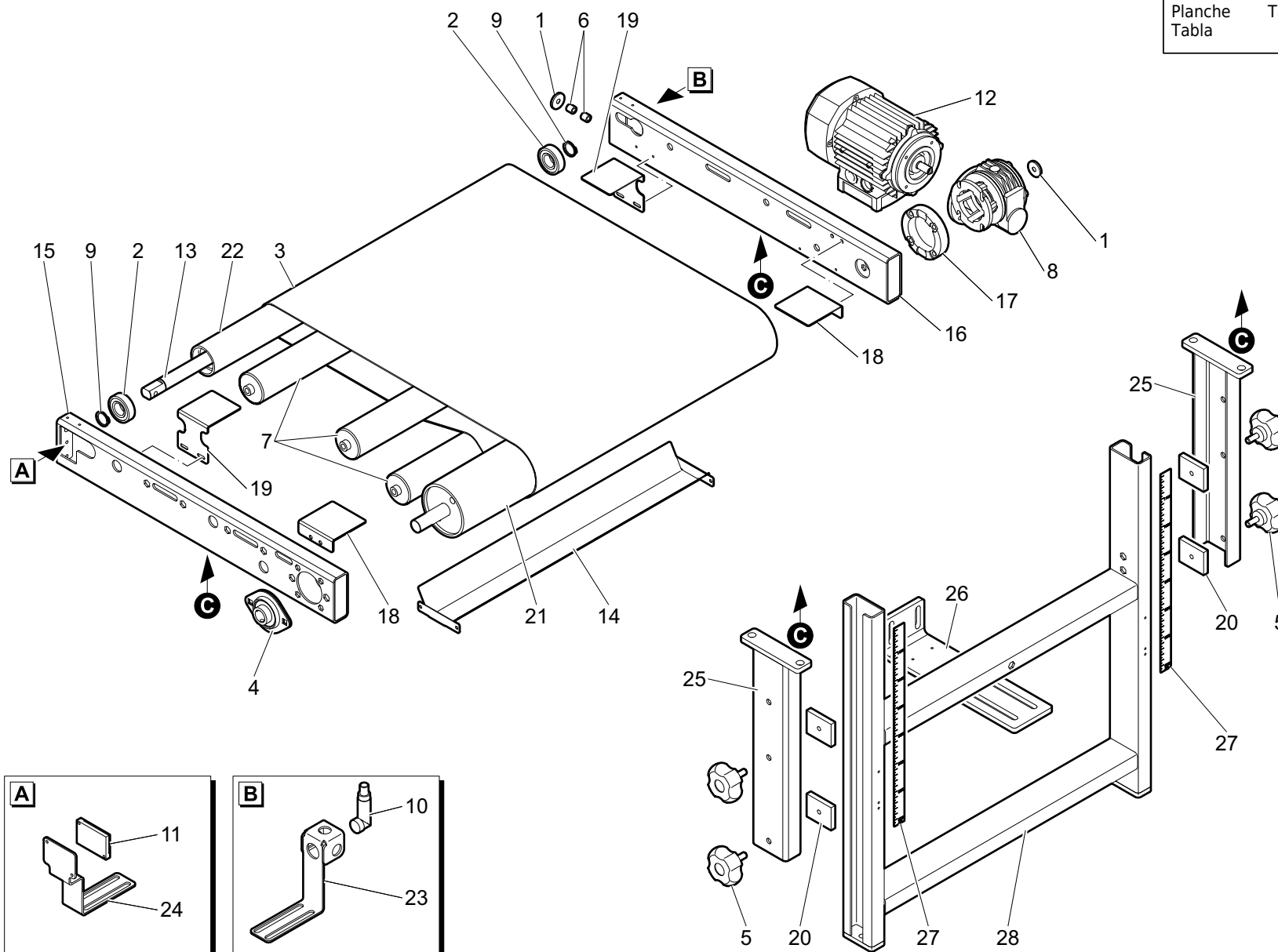

Variante rif. codice

1	0000305479
2	0000606100
3	0000609760
4	0000613239
5	0000619881
6	0000626764
7	0000641623
IN 8	0000642270
OUT 8	0000640886
9	0000644268
10	0001310180
11	0001310195
12	2212300009
13	3740300357
14	4250301053
15	4610300368
16	4610300369
17	4730300058
18	4940300939
19	4940300963
20	5330300520
21	5650300307
22	5651300219
23	5740300432
24	5740300433
25	5740300553
26	5830300477
27	5920300642
28	6040300497



Gruppo alimentazione a nastro
Bandzuführungsgruppe
Grupo alimentación de cinta

Belt infeed unit
Groupe alimentation à bande

Macchina
Maschine
Máquina

WRAPPY 9S/9A

OPT

L:1500

Tavola
Planche
Tabla

Table
Tafel

A1106_004

1/1

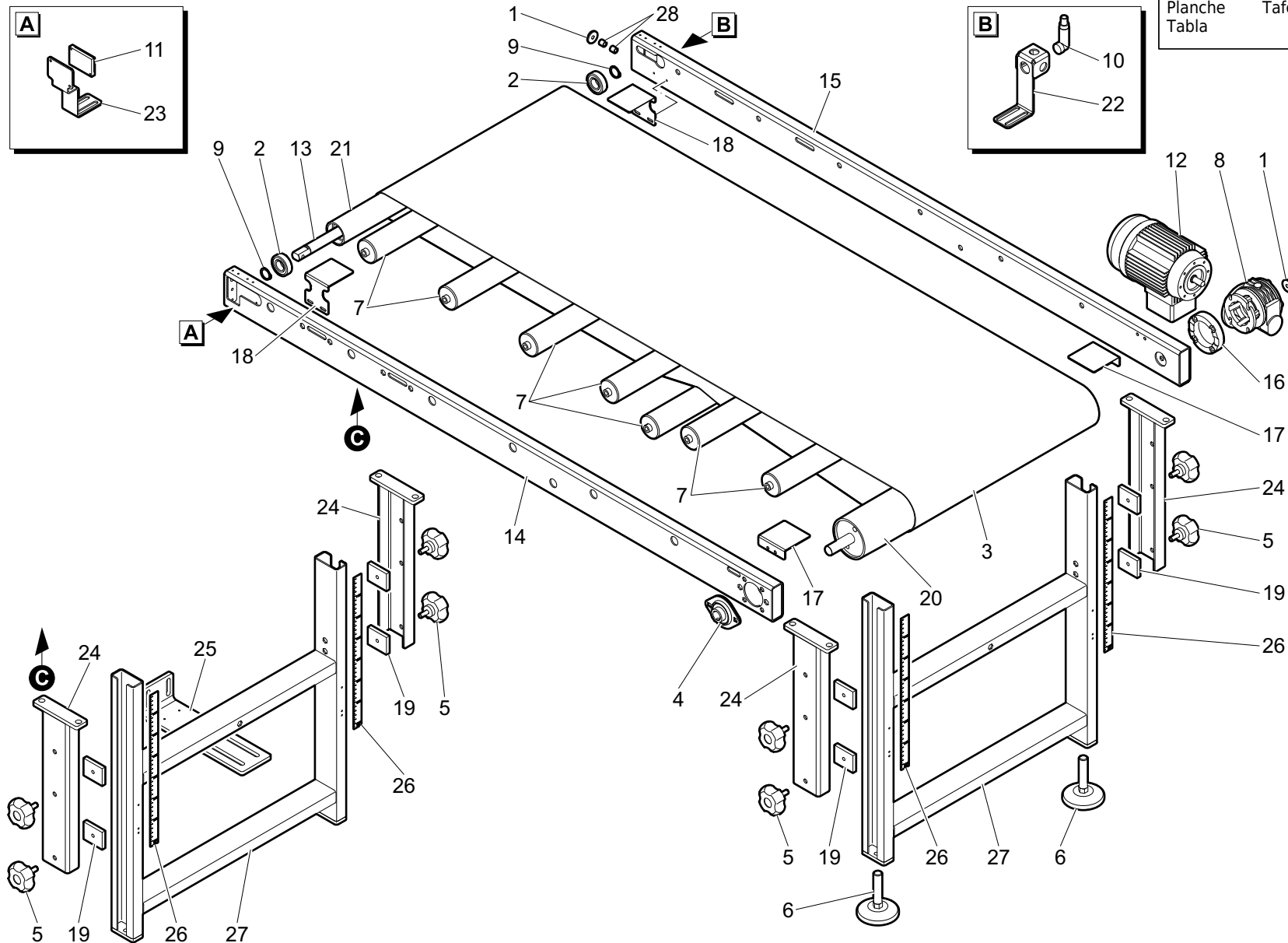
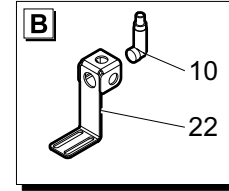
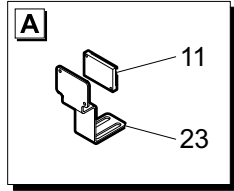

Variante rif. codice

	1	0000305479
	2	0000606100
	3	0000609790
	4	0000613239
	5	0000619829
	6	0000636584
	7	0000641623
IN	8	0000642270
OUT	8	0000640886
	9	0000644268
	10	0001310180
	11	0001310195
	12	2212300005
	13	3740300357
	14	4610300370
	15	4610300371
	16	4730300058
	17	4940300939
	18	4940300963
	19	5330300520
	20	5650300307
	21	5651300219
	22	5740300432
	23	5740300433
	24	5740300553
	25	5830300477
	26	5920300642
	27	6040300497
	28	0000626764



Gruppo alimentazione a nastro
Bandzuführungsgruppe
Grupo alimentación de cinta

Belt infeed unit
Groupe alimentation à bande

Macchina
Maschine
Máquina

Machine
Machine
Machine

WRAPPY 9S/9A

OPT

L:850 W:815

Tavola
Planche
Tabla

Table
Tafel

A1106_013

1/1

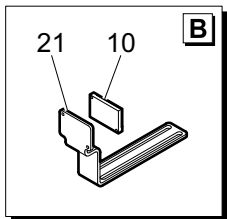
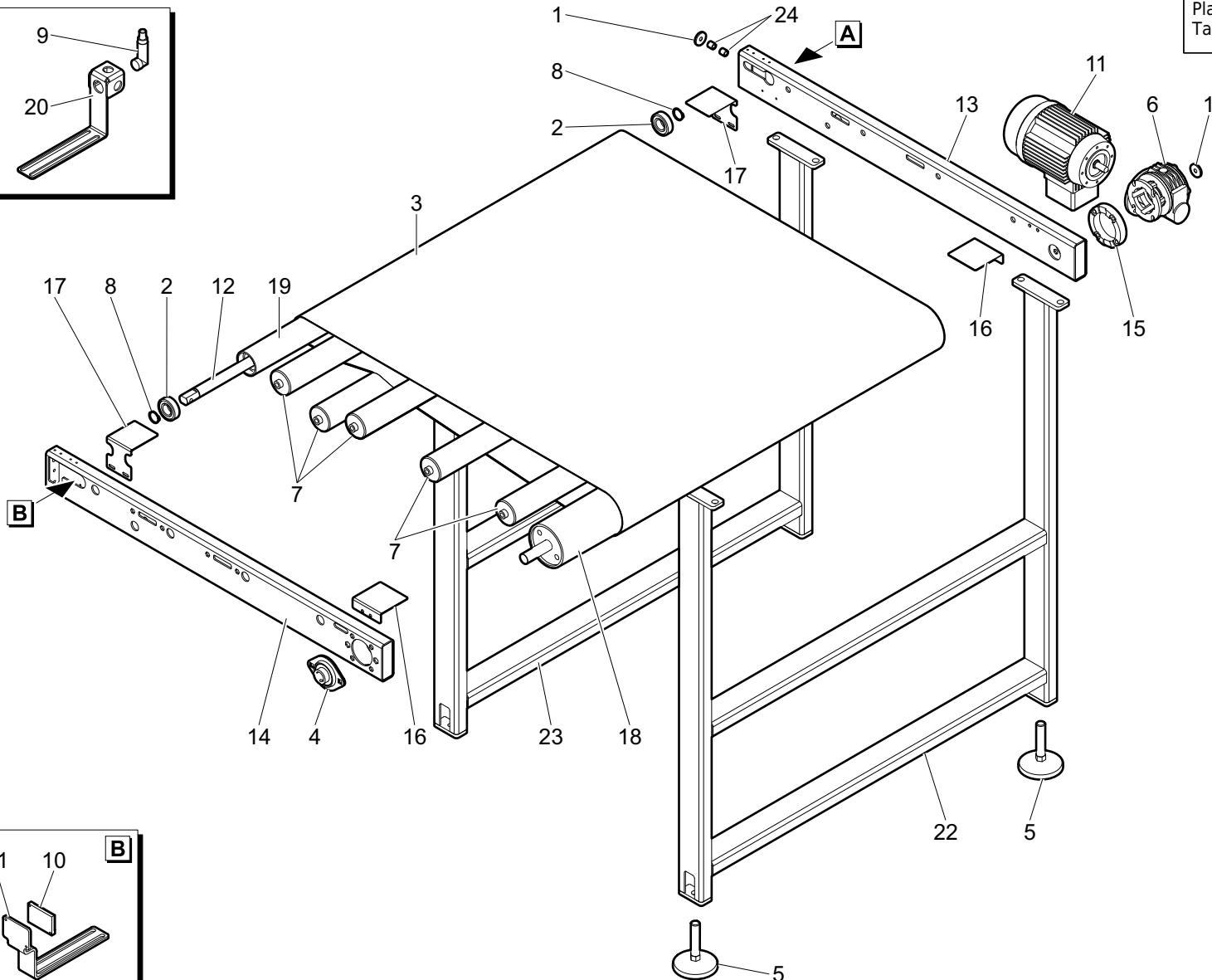
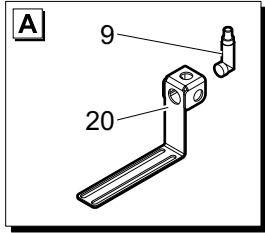

Variante rif. codice

1	0000305479
2	0000606100
3	0000609975
4	0000613239
5	0000636584
IN 6	0000638127
OUT 6	0000641244
7	0000641455
8	0000644268
9	0001310180
10	0001310195
11	2212300005
12	3740300275
13	4610300376
14	4610300377
15	4730300058
16	4940300939
17	4940300963
18	5650300310
19	5651300178
20	5740300451
21	5740300452
22	6040300541
23	6040300540
24	0000626764



Gruppo alimentazione a nastro
 Bandzuführungsgruppe
 Grupo alimentación de cinta

Belt infeed unit
 Groupe alimentation à bande

Macchina
 Maschine
 Máquina

Machine
 Machine
 Machine

WRAPPY 9S/9A

OPT

L:1500 W:815

Tavola
 Planché
 Tabla

Table
 Tafel

A1106_014

1/1

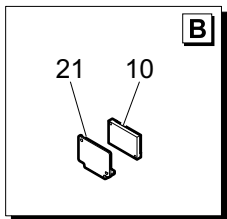
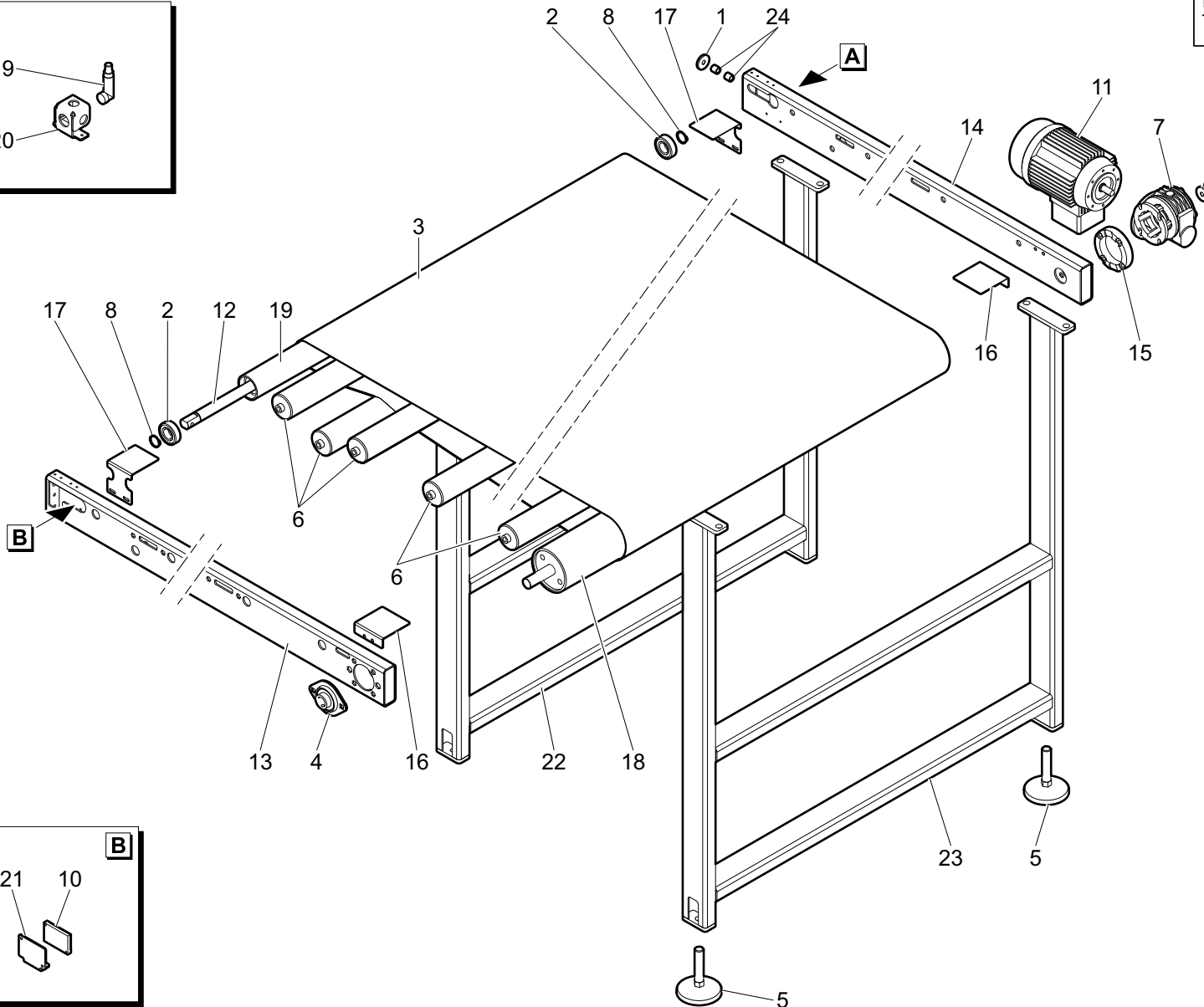
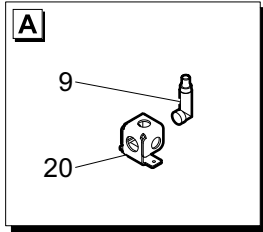

Variante rif. codice

1	0000305479
2	0000606100
3	0000609791
4	0000613239
5	0000636584
6	0000641455
IN	7 0000642270
OUT	7 0000640886
8	0000644268
9	0001310180
10	0001310195
11	2212300005
12	3740300275
13	4610300370
14	4610300371
15	4730300058
16	4940300939
17	4940300963
18	5650300310
19	5651300178
20	5740300477
21	5740300478
22	6040300540
23	6040300541
24	0000626764



Gruppo ponte Bruecke-gruppe Grupo puente	Bridge unit Groupe pont	Macchina Maschine Máquina	Machine Machine	WRAPPY 9S/9A	
OPT	BOB.125/250 W:500/815	Tavola Planche Tabla	Table Tafel	A1106_012	1/1

Variante	ref.	codice
W:815	1	5890301088
W:500	1	5890301085
BOB.250	2	4940300866
BOB.125	2	4940300864
BOB.250	3	4940300865
BOB.125	3	4940300863
	4	5330300478

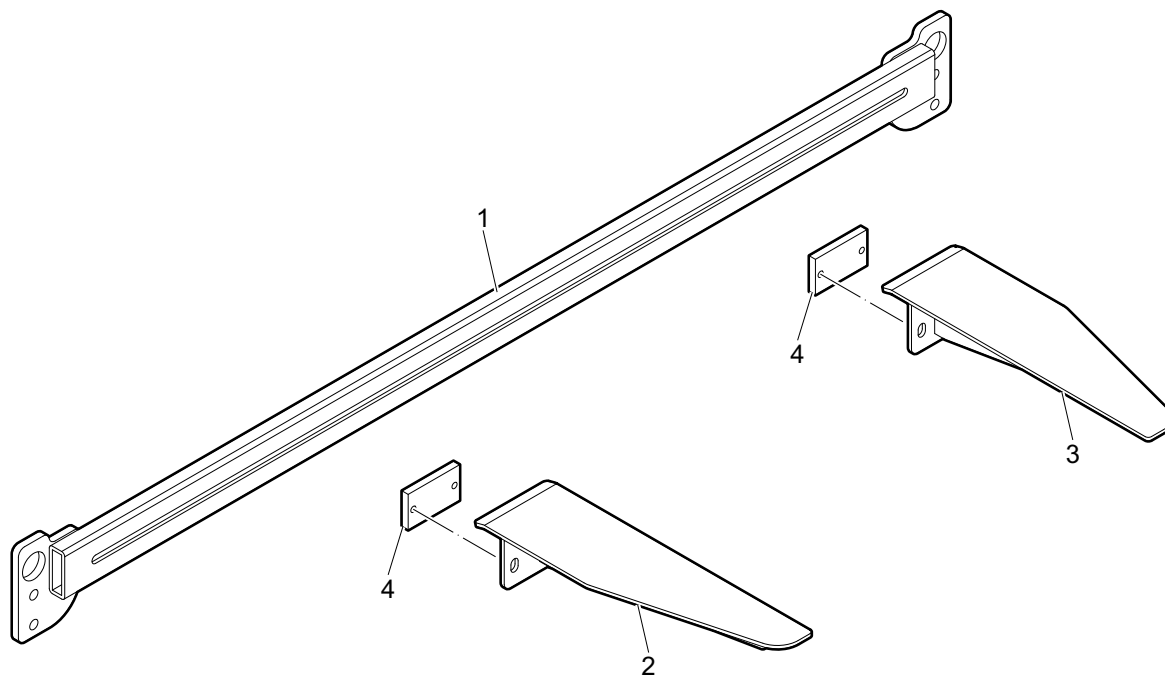



Gruppo di sollevamento (Convogliatore) Hebegruppe (Förderband) Grupo de elevación (Transportador)	Lifting unit (Carrier) Groupe de soulevement (Convoyeur)	Macchina Maschine Máquina	Machine Machine Machine	WRAPPY 9S/9A	
OPT		Tavola Planche Tabla	Table Tafel	A1106_011	1/1

Variante rif. codice

1	PROT_64017
2	5830300525

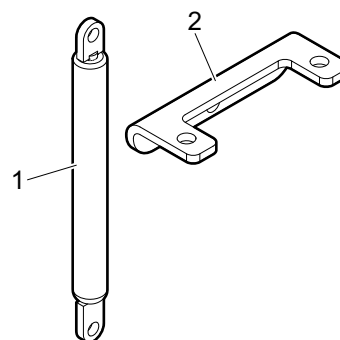
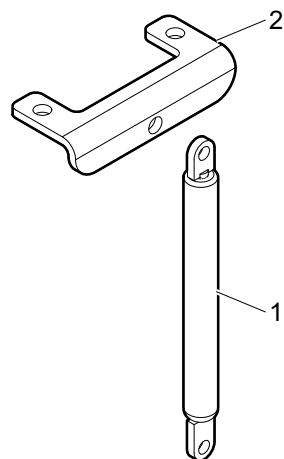



Gruppo guida laterale
 Gruppe Seitenführungen
 Grupo guía lateral

Side guide unit
 Groupe guide latéral

Macchina
 Maschine
 Máquina

Machine
 Machine
 Machine

WRAPPY 9S/9A

OPT

L:600

Tavola
 Planche
 Tabla

Table
 Tafel

A1106_005

1/1

Variante rif. codice

1	0000304245
2	0000619255
3	0000619837
4	3980300102
5	4820300546
6	4820300547
7	4820300601
8	5340300296
9	5740300557
10	5740300600
11	0000642314
12	0000642315

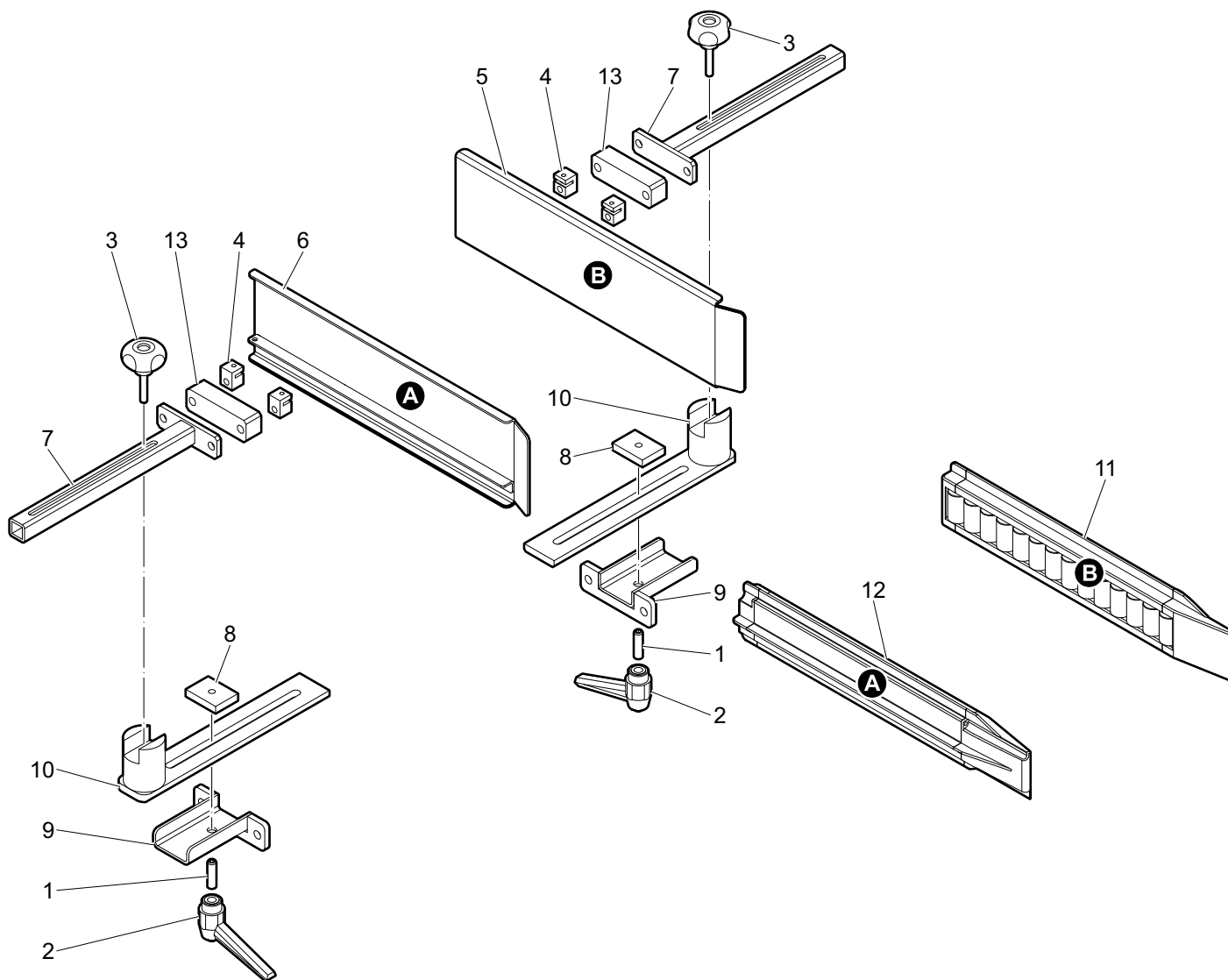



Gruppo guida laterale
 Gruppe Seitenführungen
 Grupo guía lateral

Side guide unit
 Groupe guide latéral

Macchina
 Maschine
 Máquina

Machine
 Machine
 Machine

WRAPPY 9S/9A

OPT

L:1500

Tavola
 Planche
 Tabla

Table
 Tafel

A1106_006

1/1

Variante rif. codice

1	0000304245
2	0000619255
3	0000619837
4	3980300102
5	4820300550
6	4820300551
7	4820300601
8	5340300296
9	5740300557
10	5740300600
11	0000641550
12	0000641551

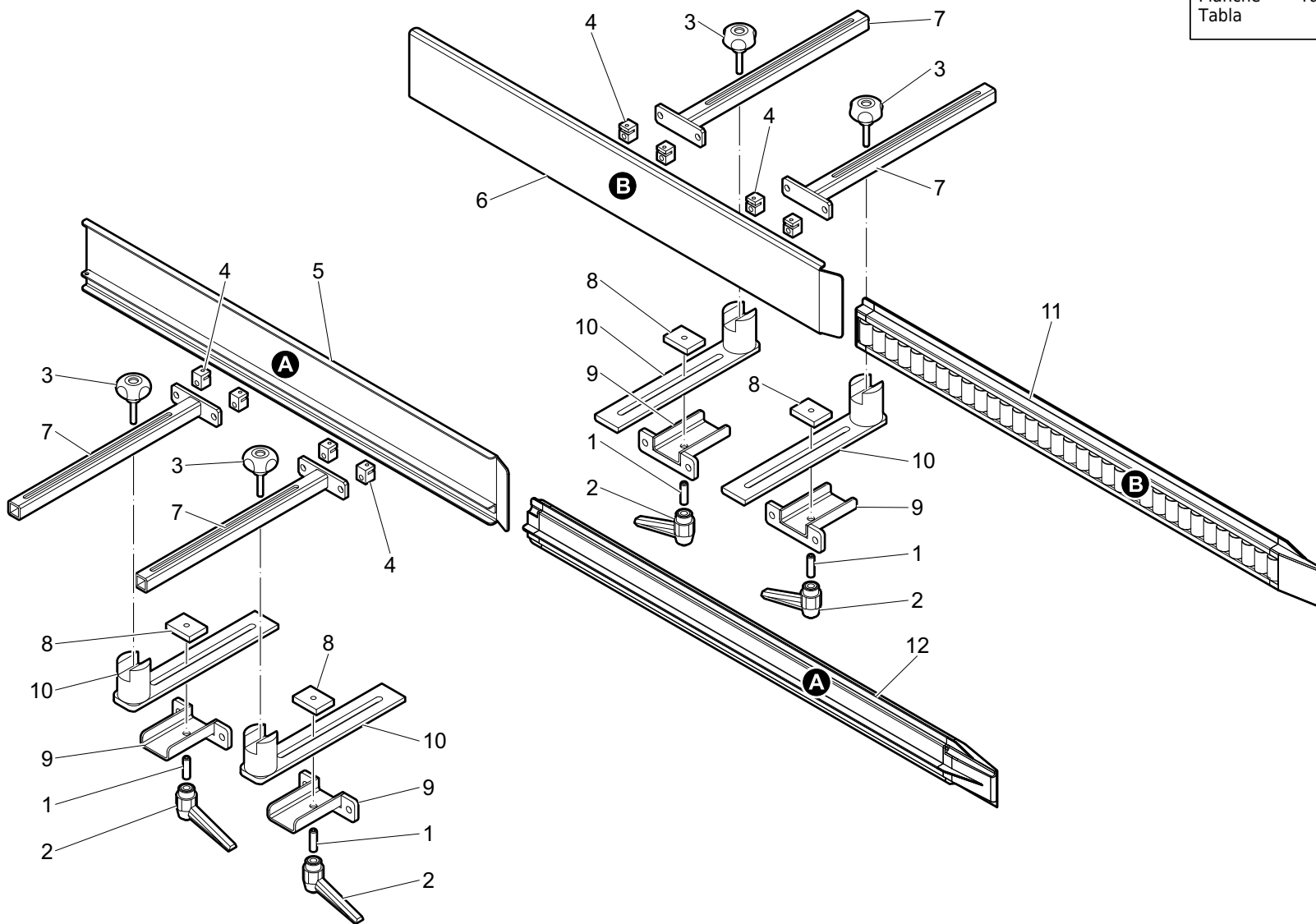



Gruppo avvolgimento
Umwickelgruppe
Grupo envoltura

Wrapping unit
Groupe banderolage

Macchina
Maschine
Máquina

Machine
Machine
Machine

WRAPPY 9S/9A

Tavola
Planche
Tabla

Table
Tafel

A1104_006

1/1

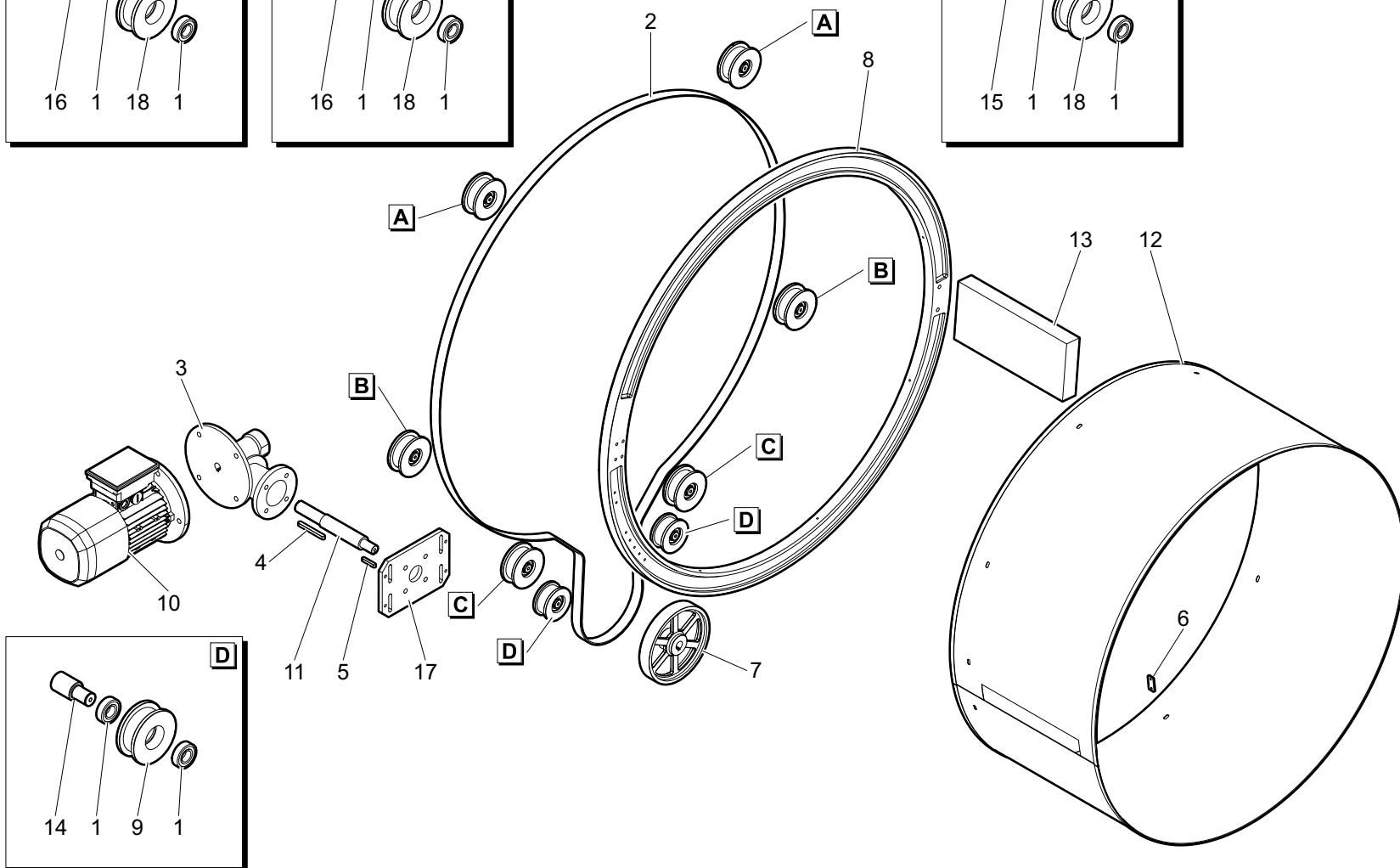
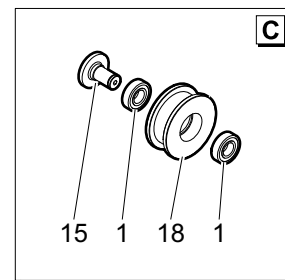
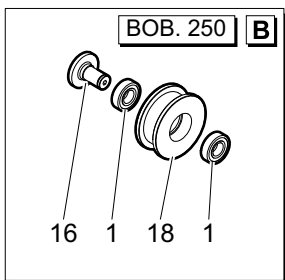
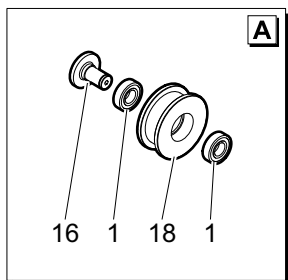

Variante rif.	codice
1	0000606100
2	0000609968
3	0000639388
4	0000645066
5	0000645183
6	0380500175
7	0380650075
8	0380670135
9	0380710045
BOB. 125 10	0001320218
BOB. 250 10	2212300012
11	3740300499
12	3770300072
BOB. 125 13	4430300007
BOB. 250 13	4430300027
14	5270300715
15	5270300734
16	5270300735
17	5330300595
18	5651300309



Gruppo portabobina
Folienrollengruppe
Grupo portabobina

Spool carriage
Groupe porte-bobine

Macchina
Maschine
Máquina

Machine
Machine
Machine

WRAPPY 9S/9A

BOB.125

Tavola
Planche
Tabla

Table
Tafel

A1104_009

1/1

Variante rif. codice

1	0000301421
2	5651300296
3	5330300596
4	5270300701
5	0000613073
6	0000613044
7	0000644258
8	5270300700
9	0380290105
10	0380300145
11	0380530115
12	0380530125
13	0380530554
14	0380540074
15	0380630044
16	0380680024
17	0380680035
18	0380690085
19	4460300001
20	4550300268
21	5123300011
22	5270300699

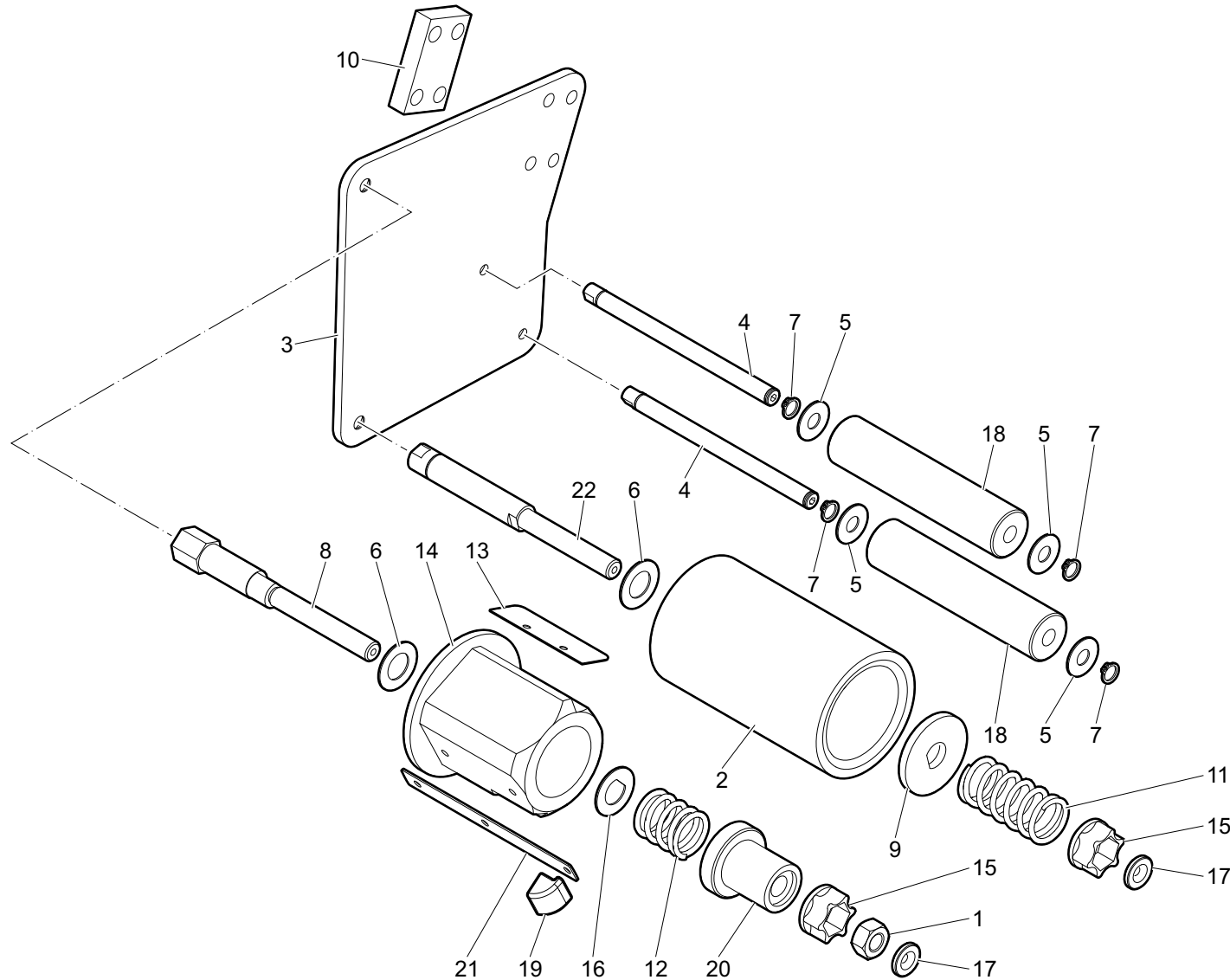



Gruppo portabobina
Folienrollengruppe
Grupo portabobina

Spool carriage
Groupe porte-bobine

Macchina
Maschine
Máquina

Machine
Machine
Machine

WRAPPY 9S/9A

BOB.250

Tavola
Planche
Tabla

Table
Tafel

A1105_010

1/1

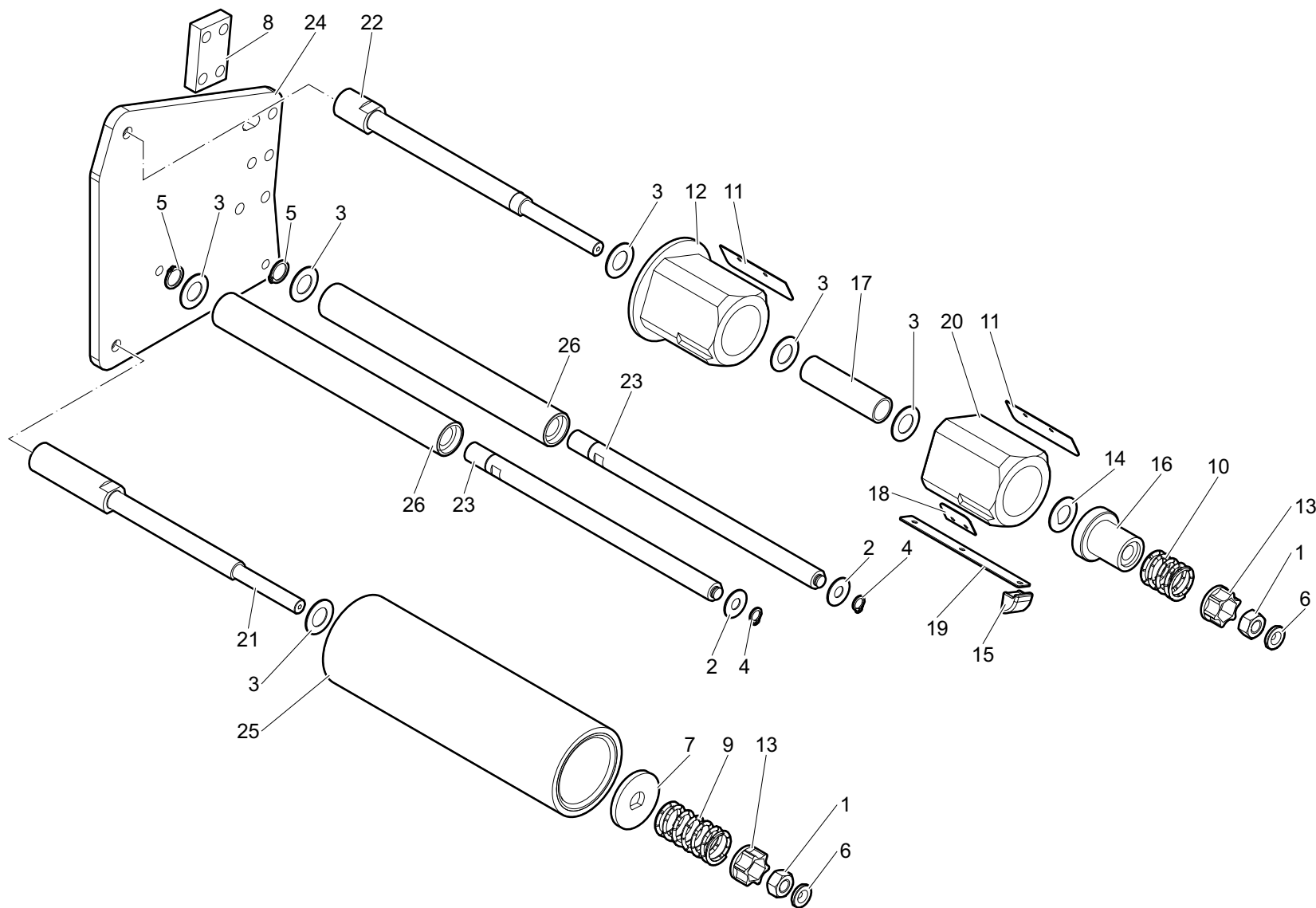

Variante rif. codice

1	000301421
2	000613073
3	000613044
4	000644258
5	000644264
6	0380680035
7	0380290105
8	0380300145
9	0380530115
10	0380530125
11	0380530554
12	0380540074
13	0380630044
14	0380680024
15	4460300001
16	4550300268
17	4550300271
18	5123300010
19	5123300011
20	5180300014
21	5270300737
22	5270300738
23	5270300739
24	5330300609
25	5651300297
26	5651300184



Gruppo portabobina + Rullo ballerino
 Folienrollengruppe + Schwingen roll
 Grupo portabobina + Rodillo oscilante

Spool carriage + Swinging roll
 Gr. porte-bobine + Rouleau oscillant

Macchina
 Maschine
 Máquina

Machine
 Machine
 Machine

WRAPPY 9S/9A

OPT

BOB.125

Tavola
 Planche
 Tabla

Table
 Tafel

A1104_010

1/1

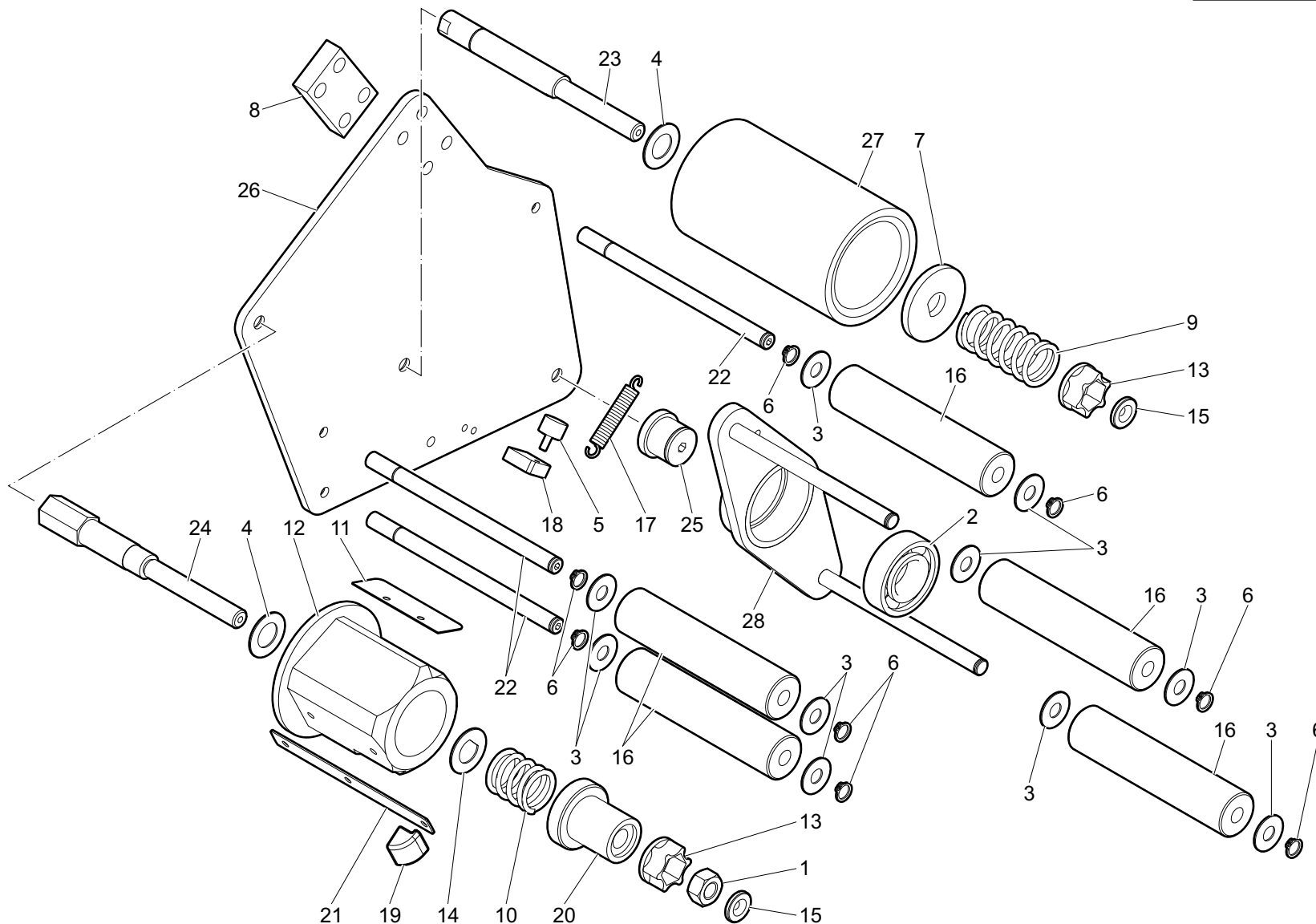

Variante rif. codice

1	000301421
2	000606110
3	000613073
4	000613044
5	000624338
6	000644258
7	0380290105
8	0380300145
9	0380530115
10	0380530125
11	0380530554
12	0380540074
13	0380630044
14	0380680024
15	0380680035
16	0380690085
17	0381530043
18	3980300121
19	4460300001
20	4550300268
21	5123300011
22	5270300703
23	5270300704
24	5270300705
25	5270300706
26	5330300610
27	5651300296
28	6040300489



Gruppo portabobina + Rullo ballerino
 Folienrollengruppe + Schwingen roll
 Grupo portabobina + Rodillo oscilante

Spool carriage + Swinging roll
 Gr. porte-bobine + Rouleau oscillant

Macchina
 Maschine
 Máquina

Machine
 Machine
 Machine

WRAPPY 9S/9A

OPT

BOB.250

Tavola
 Planche
 Tabla

Table
 Tafel

A1105_011

1/2

Variante rif. codice

1	6040300488
2	0000301421
3	5651300297
4	5651300184
5	5330300610
6	5270300739
7	0000606110
8	0000613044
9	0000613073
10	0000624338
11	0000644258
12	0000644264
13	0000644273
14	0380290105
15	0380300145
16	0380530115
17	0380530125
18	0380530554
19	0380540074
20	0380630044
21	0380680024
22	0380680035
23	0381530043
24	3980300121
25	4460300001
26	4550300268
27	4550300271
28	5123300010
29	5123300011
30	5180300014
31	5270300706

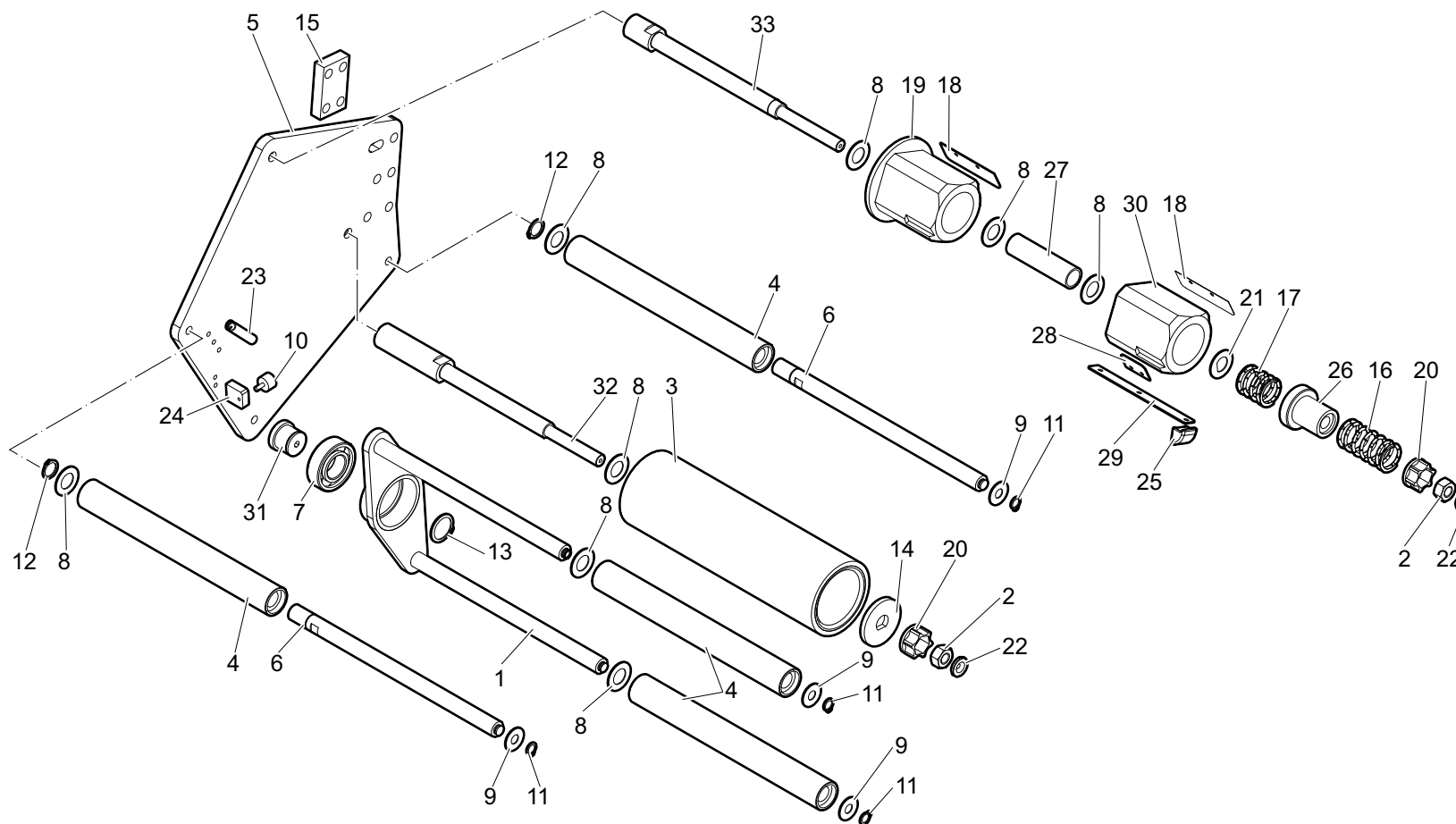



Gruppo portabobina + Rullo ballerino
 Folienrollengruppe + Schwingen roll
 Grupo portabobina + Rodillo oscilante

Spool carriage + Swinging roll
 Gr. porte-bobine + Rouleau oscillant

Macchina
 Maschine
 Máquina

Machine
 Machine
 Machine

WRAPPY 9S/9A

OPT

BOB.250

Tavola
 Planche
 Tabla

Table
 Tafel

A1105_011

2/2

Variante rif. codice

32 5270300737

33 5270300738

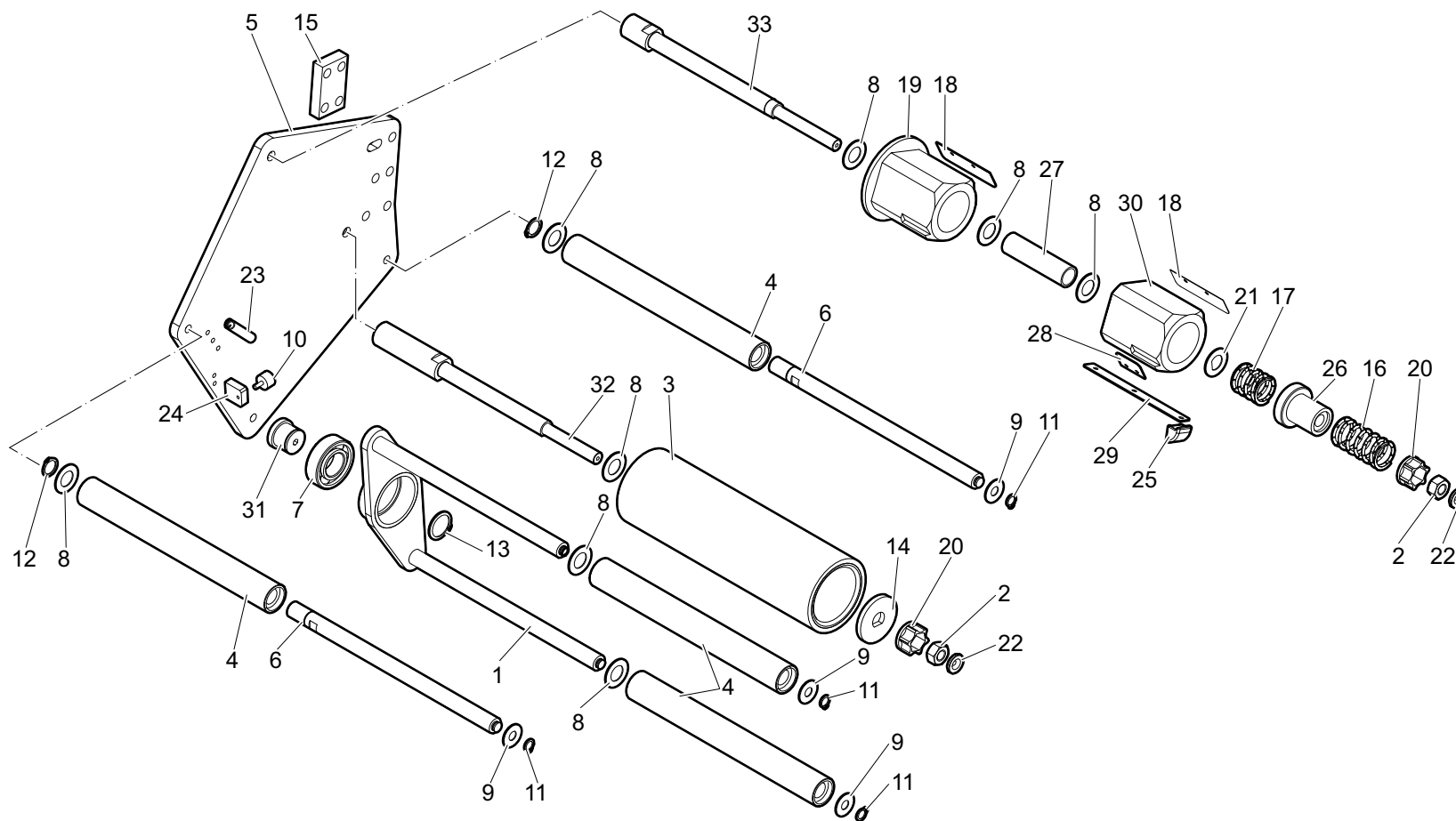



Gruppo pinza/taglio
Spannzangen/schneide-einheit
Grupo pinza/corte

Pliers/cutting unit
Groupe pince/deco upage

Macchina
Maschine
Máquina

Machine
Machine
Machine

WRAPPY 9S/9A

BOB.125/250

Tavola
Planche
Tabla

Table
Tafel

A1106_007

1/1

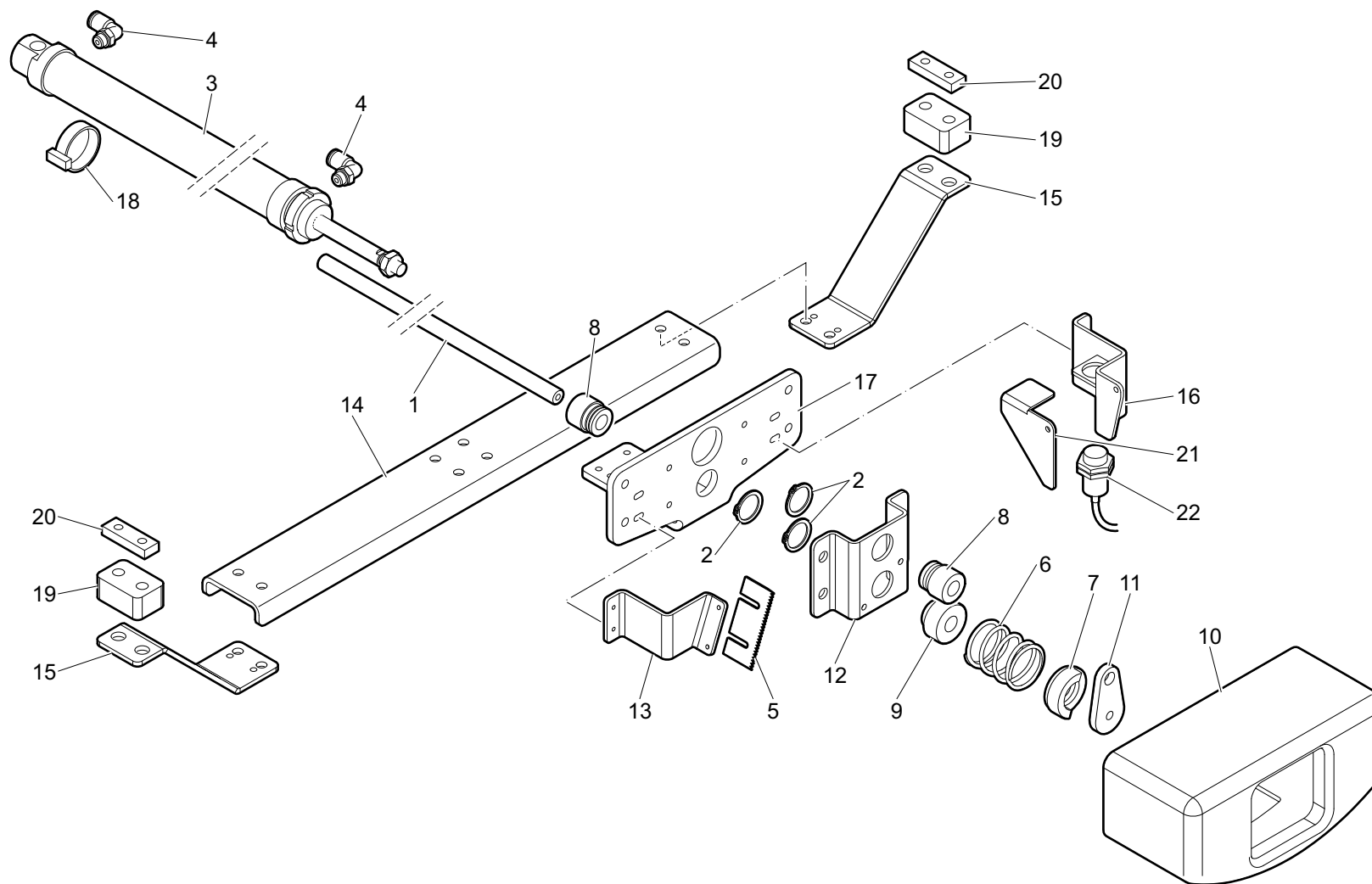

Variante rif. codice

BOB.125	1	PROT_62534
BOB.250	1	PROT_63084
	2	0000644270
BOB.125	3	0001502920
BOB.250	3	0001503171
	4	0001905014
	5	0380490014
	6	0380530075
	7	4040300060
	8	4040300061
	9	4040300062
	10	4250301109
	11	4940300980
	12	4940300981
	13	4940300982
	14	5740300614
	15	5830300476
	16	5890301381
	17	5890301382
BOB.250	18	0001301195
	19	4550300275
	20	5330300608
	21	4940300983
	22	0001300299



Gruppo pinza/taglio
Spannzangen/schneide-einheit
Grupo pinza/corte

Pliers/cutting unit
Groupe pince/deco upage

Macchina
Maschine
Máquina

Machine
Machine
Machine

WRAPPY 9S/9A

W:815 BOB.125/250

Tavola
Planche
Tabla

Table
Tafel

A1106_008

1/1

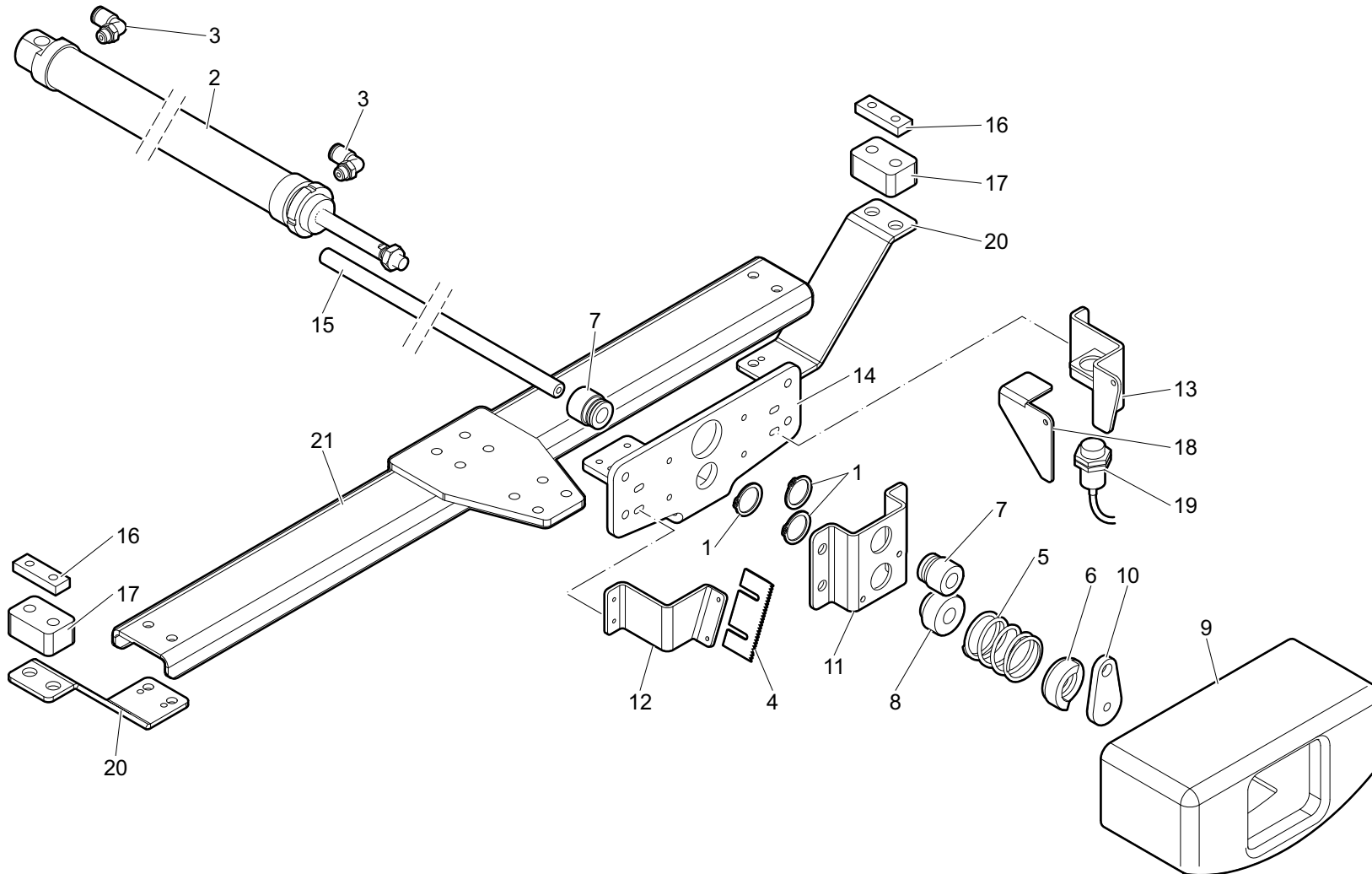

Variante rif. codice

	1	000644270
BOB.250	2	0001503171
BOB.125	2	0001502920
	3	0001905014
	4	0380490014
	5	0380530075
	6	4040300060
	7	4040300061
	8	4040300062
	9	4250301109
	10	4940300980
	11	4940300981
	12	4940300982
	13	5890301381
	14	5890301382
BOB.250	15	PROT_63084
BOB.125	15	PROT_62534
	16	5330300608
	17	4550300275
	18	4940300983
	19	0001300299
	20	5830300476
	21	5740300620



Gruppo pressore
Niederhaltergruppe
Grupo presor

Pressure platen unit
Groupe presseur

Macchina
Maschine
Máquina

Machine
Machine
Machine

WRAPPY 9S/9A

L:400-600 BOB.125-250

Tavola
Planche
Tabla

Table
Tafel

A1106_009

1/1

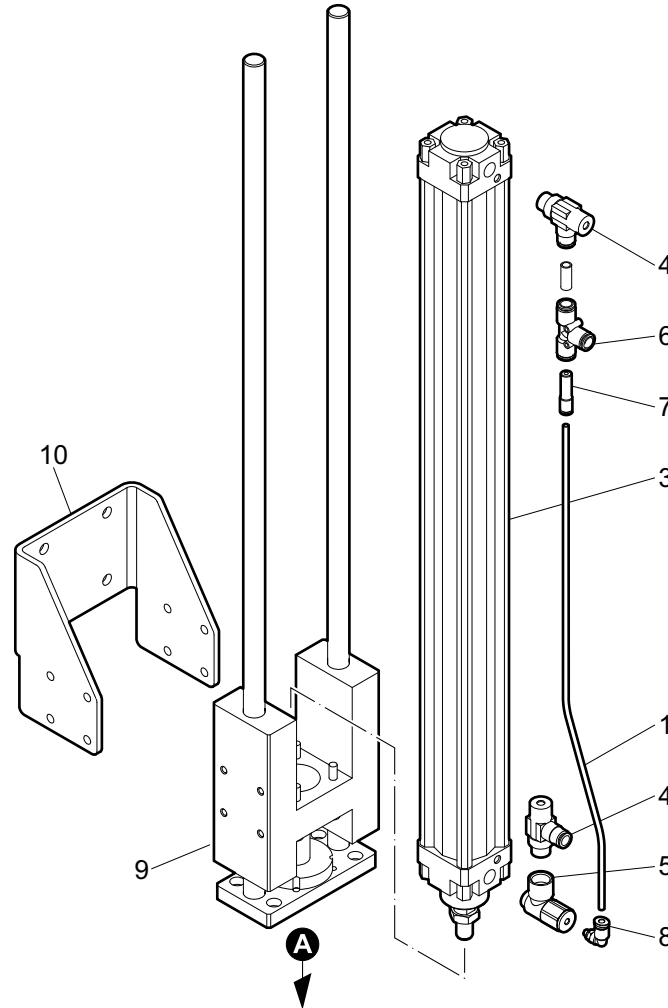
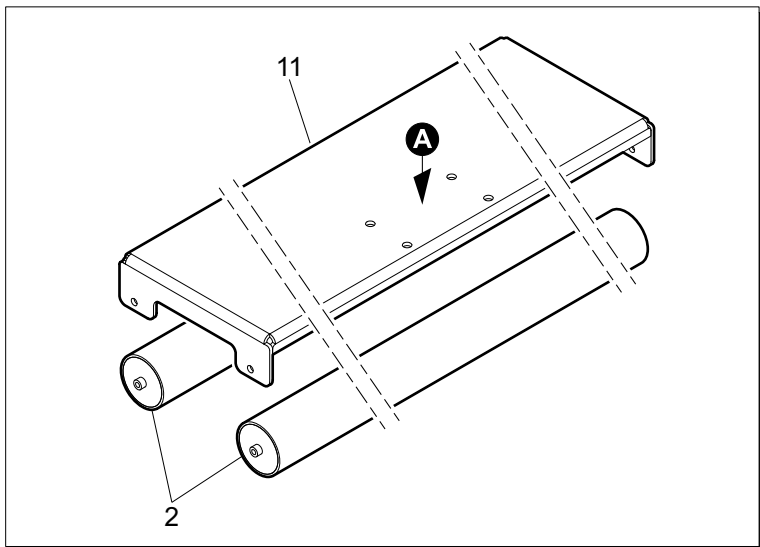
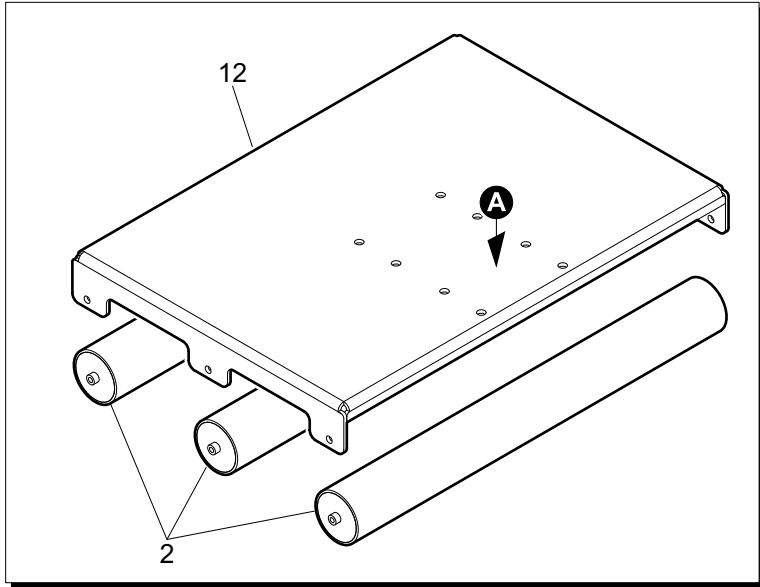

Variante rif. codice

	1	000640277
L:400	2	000642460
L:600	2	000641453
	3	0001500276
	4	0001508834
	5	0001509313
	6	0001900078
	7	0001900126
	8	0001904353
	9	-
	10	5740300630
BOB.250 L:400	11	5890301515
L:600	11	5890301523
BOB.125 L:400	12	5890301520



Impianto pneumatico
Pneumatische anlage
Instalacion neumatica

Pneumatic system
Circuit pneumatique

Macchina
Maschine
Máquina

Machine
Machine
Machine

WRAPPY 9S/9A

Tavola
Planche
Tabla

Table
Tafel

A1208_004

1/1

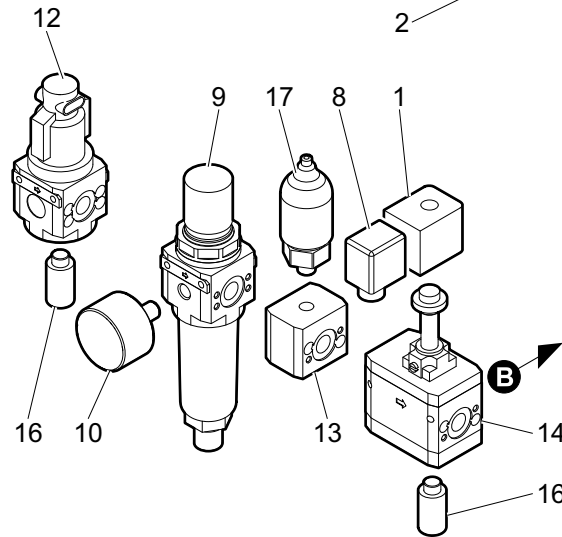
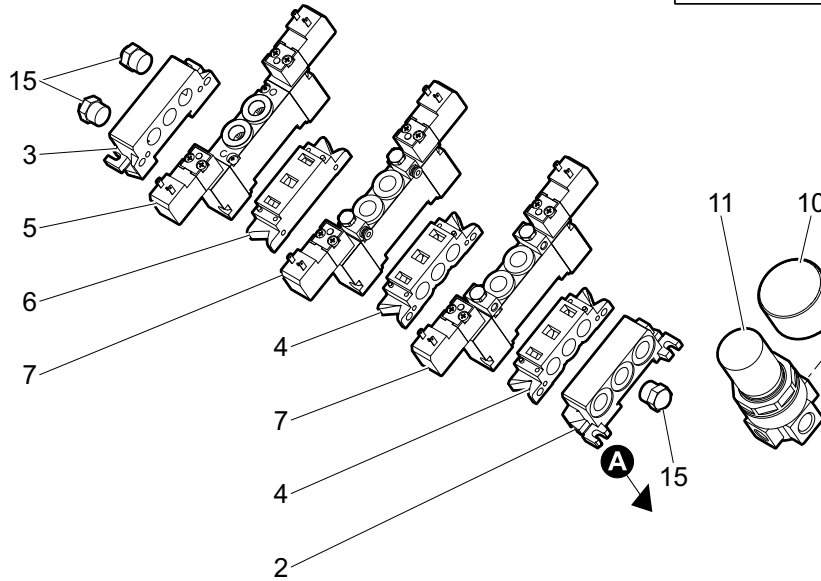
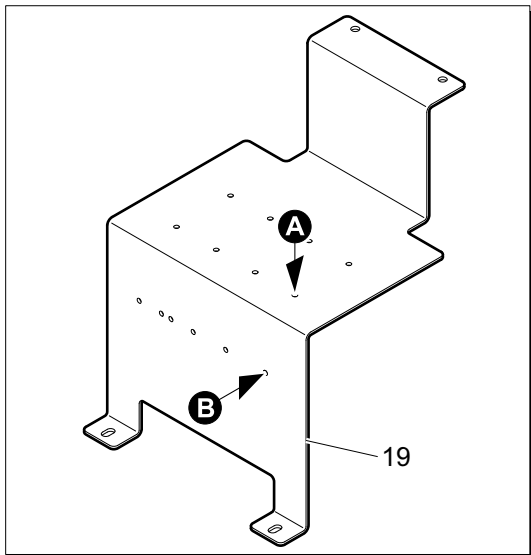
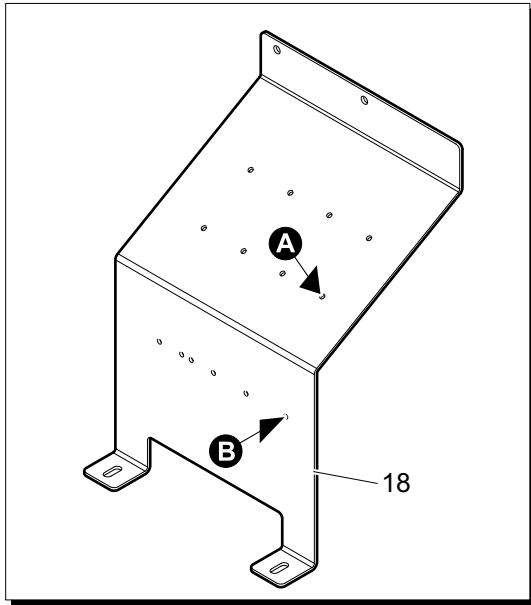

Variante rif. codice

1	0001301019
2	0001344464
3	0001344466
4	0001344467
5	0001344523
6	0001344557
7	0001344566
8	0001353240
9	0001500957
10	0001505030
11	0001508826
12	0001510013
13	0001510488
14	0001900086
15	0001908066
16	0001908230
17	2010300001
9S 18	4940300995
9A 19	4940301099



Gruppo convogliatore folle
 Einheit förderer
 Grupo transportador

Idle conveyor unit
 Groupe convoyeur fou

Macchina
 Maschine
 Máquina

Machine
 Machine
 Machine

WRAPPY 9S/9A

OPT

L:1000W:650

Tavola
 Planche
 Tabla

Table
 Tafel

A1104_014

1/1

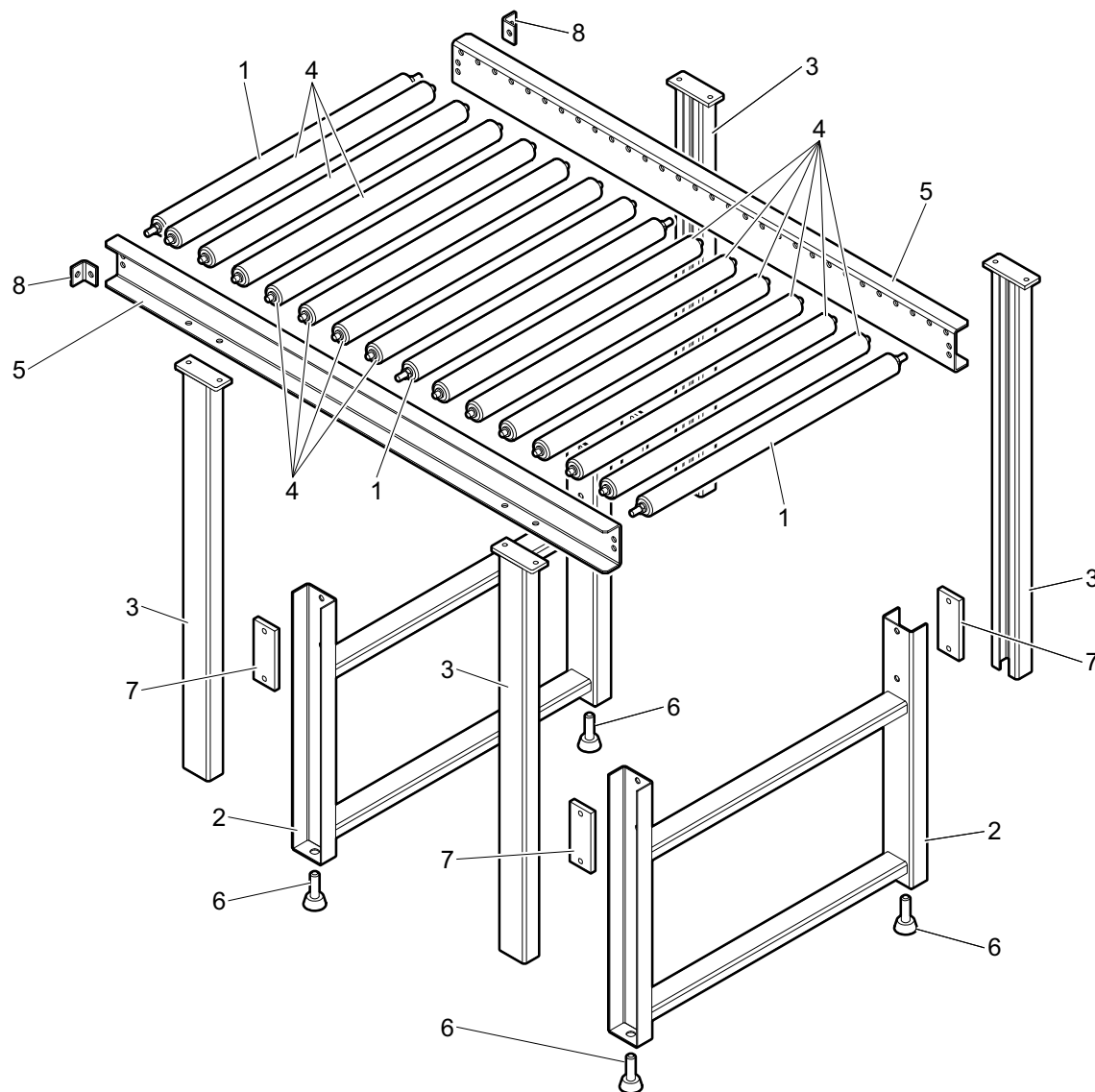

Variante rif. codice

1	000638254
2	0580760384
3	4820300517
4	000638249
5	0380330184
6	0580620014
7	0380602334
8	0380501224



Gruppo convogliatore folle
 Einheit förderer
 Grupo transportador

Idle conveyor unit
 Groupe convoyeur fou

Macchina
 Maschine
 Máquina

Machine
 Machine
 Machine

WRAPPY 9S/9A

OPT

L:2000W:650

Tavola
 Planche
 Tabla

Table
 Tafel

A1104_015

1/1

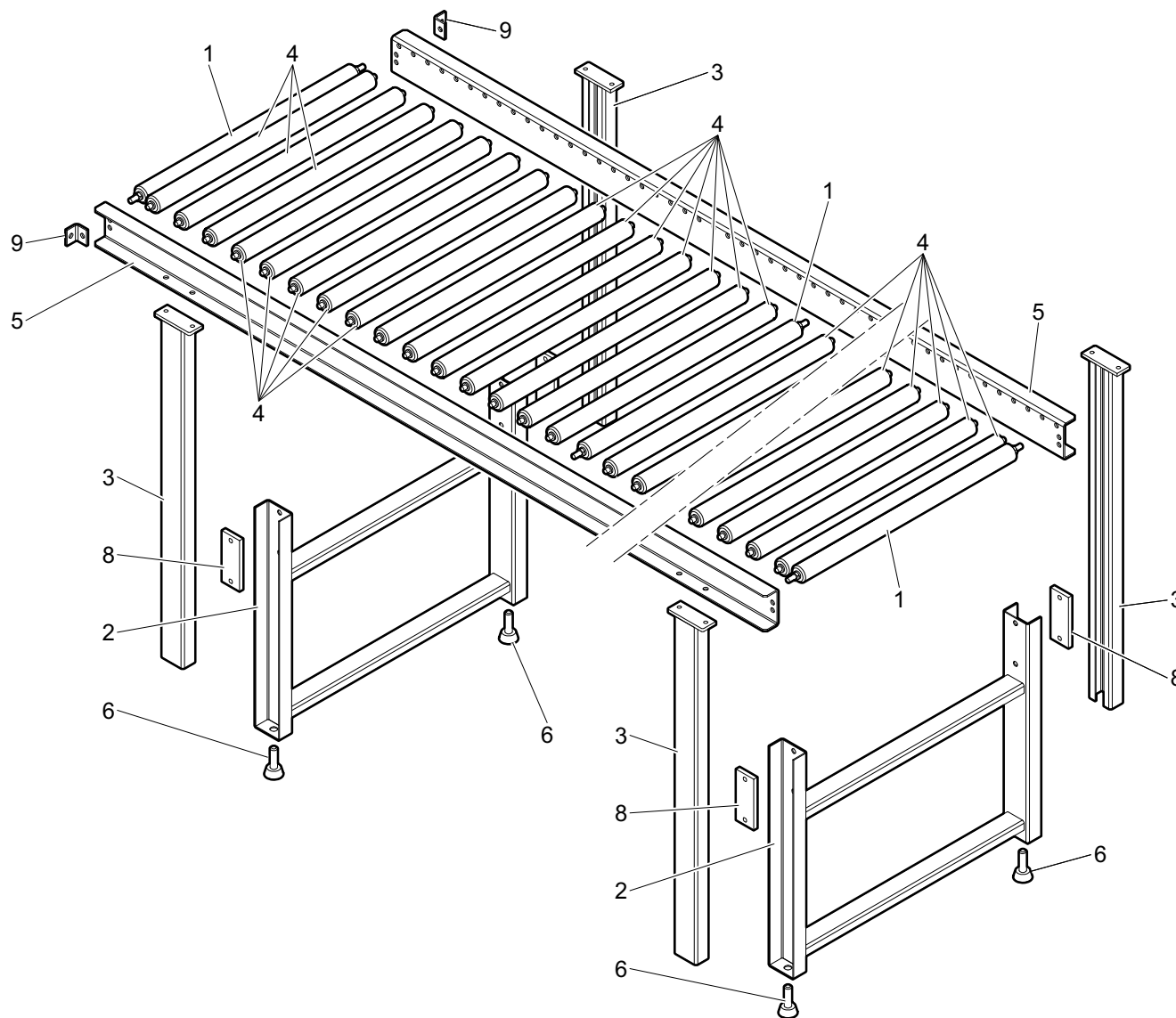

Variante rif. codice

1	000638254
2	0580760384
3	4820300517
4	000638249
5	0380330204
6	0580620014
7	000301421
8	0380602334
9	0380501224



Kit targhette
Schild
Kit placas

Plate kit
Kit de plaquettes

Macchina Maschine Máquina	Machine Machine Machine	WRAPPY 9S/9A	
Tavola Planche Tabla	Table Tafel	A1208_005	1/1

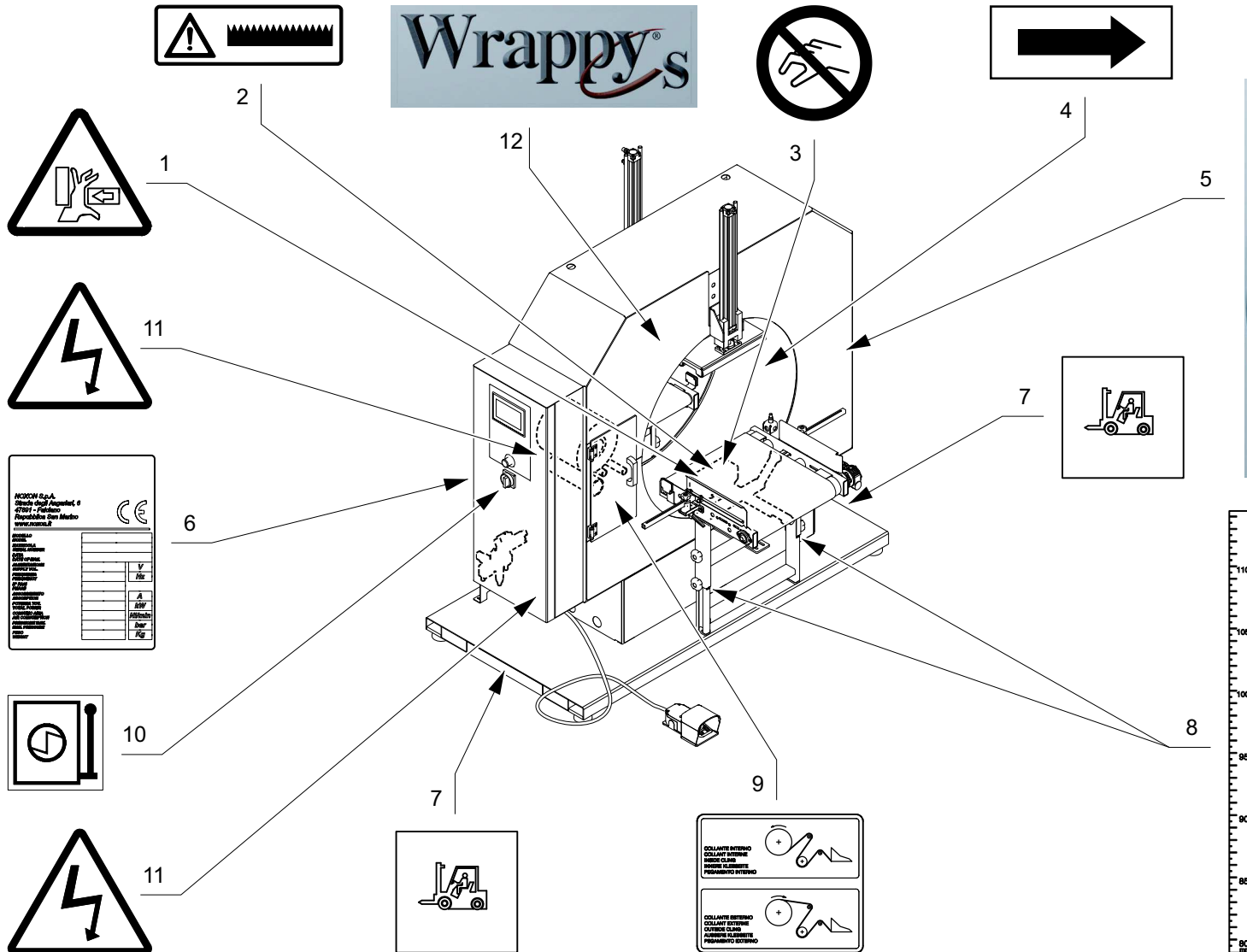

Variante rif. codice

1	5920300682
2	0380810035
3	5920300200
4	0380810270
5	5920300667
6	0380810425
7	5920300101
8	5920300688
9	5920300686
OPT 9	5920300687
10	5920300646
11	0381810287
9S 12	5920300729
9A 12	5920300731



I	Scheda di ordinazione parti di ricambio
GB	Spare parts order form
D	Bestellblatt für Ersatzteile
F	Fiche de commande pièces détachées
E	Ficha de pedido de piezas de repuesto

Modello _____	Data ordine _____	Mittente _____
Model • Modell _____	Order date • Bestelldatum _____	Sender • Besteller _____
Modèle • Modelo _____	Date commande • Fecha de pedido _____	Expéditeur • Remitente _____
Matricola _____	Modo di spedizione _____	Agente _____
Serial number • Seriennummer _____	Delivery method • Versandart _____	Agent • Vertreter _____
Matricule • Número de matricula _____	Moyen d'expédition • Modo de envío _____	Agent • Agente _____

N° di tavola Table number Nummer der Tafel N° de planche N° de tabla	N° Pos. Position Number Artikelnummer N° Pos. N° Pos.	Codice Code Code Código	Qt. Quantity Menge Q.té Cant.	Descrizione aggiuntiva/colore Additional description/color Zusätzliche Beschreibung/Farbe Informations supplémentaires/couleur Descripción adicional/color	Note Notes Anmerkungen Note Notas

Per richieste e ordinazioni, rivolgersi all'agente di zona o direttamente a:
 For requests and orders please contact the area agent or:
 Für Anfragen und Bestellungen wenden Sie sich bitte an Ihren Bezirksvertreter, oder direkt an:
 Pour demandes et commandes, s'adresser à l'agent de zone ou directement à:
 Para aclaraciones y pedidos, dirigirse al agente de zona o directamente a:

NOXON S.p.A.
 Strada degli Angiari, 6
 47891 FALCIANO E-6 • Repubblica S.Marino (RSM)
 Tel. 0549 (international ++378) 977419 • Fax. 0549 (international ++378) 908549
<http://www.noxon.com>