



Strada Molino Magi, 66
47892 Gualdicciolo
Tel +378 0549 941426 Fax +378 0549 941426
Repubblica di San Marino

Modello Macchina
Machine Model
Maschine Modell
Modele de la Machine
Modelo Maquina

Mas Pvs

Numero Matricola
Machine Serial Number
Maschine Kennummer
Numero de Matricule
Numero de Matricula

Tensione di alimentazione
Power Supply Voltage
Spannungsversorgung
Voltage electrique
Tension de Alimentacion

230 V 50 Hz
1 Ph + N

Potenza Installata
Installed Power
Installierte Leistung
Puissance installée
Potencia Instalada

0.5 kW

Corrente Assorbita
Absorbed Current
Stromaufnahme
Absorption Electrique
Absorcion

2 A

For Robopac Use Only

Codice Quadro Elettrico

7450304744

Indice Modifica

00

Numero Bolla

Costruire secondo specifica tecnica 50.1.1
Controllare con scheda di collaudo

PVS

Elaborato da

Brizi A.

Verificato da

Delbaldo L.

Approvato da

Laghi P.



Description

**Copertina
Cover sheet**

Code 3709301174

Date 15/01/2016

Total 40

Prev

Subs 2

Page

Machine

Mas Pvs

1

Sommario delle pagine

Table of contents

Impianto Higher-level function	Luogo di montaggio Mounting location	Pagina Page	Descrizione pagina Page description	Campo aggiuntivo delle pagine supplementary page field	Data Date	Elaboratore Edited by
		1	Copertina Cover sheet		15/01/2016	abrizi
		2	Sommario delle pagine : /1 - /19 Table of contents : /1 - /19		01/02/2016	abrizi
		2.1	Sommario delle pagine : /20 - /36 Table of contents : /20 - /36		01/02/2016	abrizi
		2.2	Sommario delle pagine : /37 - /42 Table of contents : /37 - /42		01/02/2016	abrizi
		4	Targhetta quadro elettrico Plate control cabinet		15/01/2016	abrizi
		5	Distinta articoli Parts list		22/01/2016	abrizi
		5.1	Distinta articoli Parts list		22/01/2016	abrizi
		10	Alimentazione Power supply		25/01/2016	abrizi
		11	Circuito di potenza Power circuit		22/01/2016	abrizi
		13	Circuito di potenza Power circuit		22/01/2016	abrizi
		14	Circuito ausiliario Auxiliary circuit		22/01/2016	abrizi
		15	Circuito ausiliario Auxiliary circuit		01/02/2016	abrizi
		16	Circuito ausiliario Auxiliary circuit		22/01/2016	abrizi
		17	Circuito ausiliario Auxiliary circuit		01/02/2016	abrizi
		18	Circuito ausiliario Auxiliary circuit		25/01/2016	abrizi
		19	Circuito ausiliario Auxiliary circuit		22/01/2016	abrizi



Description

Sommario delle pagine : /1 - /19
Table of contents : /1 - /19

Code

3709301174

Date

15/01/2016

Total

40

Prev

1

Subs

2.1

Page

2

Machine

Mas Pvs

Sommario delle pagine

Table of contents

Impianto Higher-level function	Luogo di montaggio Mounting location	Pagina Page	Descrizione pagina Page description	Campo aggiuntivo delle pagine supplementary page field	Data Date	Elaboratore Edited by
		20	Circuito ausiliario Auxiliary circuit		25/01/2016	abrizi
		21	Layout		22/01/2016	abrizi
		22	Layout		22/01/2016	abrizi
		23	Layout		22/01/2016	abrizi
		24	Sommario cavi Cable overview		22/01/2016	abrizi
		25	Morsettiera di potenza Power terminal strip		25/01/2016	abrizi
		26	Morsettiera generale General terminal strip		22/01/2016	abrizi
		27	Morsettiera generale General terminal strip		25/01/2016	abrizi
		28	Morsettiera generale General terminal strip		01/02/2016	abrizi
		29	Connettore batteria Battery connecotr		25/01/2016	abrizi
		30	Connettore batteria Battery connecotr		22/01/2016	abrizi
		31	Connettore carrello Carriage connector		22/01/2016	abrizi
		32	Connettore carrello Carriage connector		25/01/2016	abrizi
		33	Connettore motore carrello Carriage motors connector		22/01/2016	abrizi
		34	Connettore motore carrello Carriage motors connector		25/01/2016	abrizi
		35	Connettore pulsantiera Push button connector		01/02/2016	abrizi
		36	Connettore pulsantiera Push button connector		01/02/2016	abrizi



Description

Sommario delle pagine : /20 - /36
Table of contents : /20 - /36

Sommario delle pagine

Table of contents

Impianto Higher-level function	Luogo di montaggio Mounting location	Pagina Page	Descrizione pagina Page description	Campo aggiuntivo delle pagine supplementary page field	Data Date	Elaboratore Edited by
		37	Connettore palo Mast connector		01/02/2016	abrizi
		38	Connettore palo Mast connector		25/01/2016	abrizi
		39	Connettore lampeggiatore Lamp connector		25/01/2016	abrizi
		40	Connettore lampeggiatore Lamp connector		22/01/2016	abrizi
		41	Connettore cat.p.cavo Connettore cat.p.cavo		25/01/2016	abrizi
		41.a	Connettore cat.p.cavo Connettore cat.p.cavo		25/01/2016	abrizi
		42	Connettore cat.p.cavo Connettore cat.p.cavo		25/01/2016	abrizi



Description

Sommario delle pagine : /37 - /42
Table of contents : /37 - /42

		S/N	7450304744	
		Mod.	Mas Pvs	
		w.d.		
N.		Ref.		 <input type="text"/> Kg
Un	230 V	V	Ph	1 Ph + N
			f	<input type="text"/> Hz
In	2	A	Ik	10
			Ka	50 Hz
Data	<input type="text"/>		<input type="text"/>	By <input type="text"/>



Description

Targhetta quadro elettrico
Plate control cabinet

Code 3709301174

Date 15/01/2016

Total 40

Prev 2.2

Subs 5

Page

Machine

Mas Pvs

Distinta articoli

Parts list

F01_ART_0000

SEF	Designazione Designation	Numero tipo Type number	Produttore Manufacturer	Quantità Quantity	Codice Code	Pagina Page
-X0.2	Connettore 2P 50A Connector 2P 50A	6331G1-BK	Anderson Power Products	1	00L0026523A	/10.0
-X0.1	Connettore 2P 50A Connector 2P 50A	6331G1-BK	Anderson Power Products	1	00L0026523A	/10.0
-X0.1	Maniglia Handle	995G50-BK	Anderson Power Products	1	00L0026524C	/10.0
-FU1	Fusibile Cilindrico 14x51 GG 50A 500VAC Cylindrical Fuse 14x51 GG 50A 500VAC	14x51 GG 50A 500VAC		1	0001304227B	/10.0
-FU1	Base per fusibile 14 X 51 Base for fuse 14 X 51	14X51 1P		1	0001352426C	/10.0
-FU2	Fusibile Cilindrico 5x20 4A Ritardato Cylindrical Fuse 5x20 4A T	5x20 RIT 4A 500VAC		1	0001304080H	/10.3
-FU2	Morsetto portafusibile Terminal block for fuse	2002-1611	WAGO	1	00L0074329H	/10.3
-X20.1	Connettore maschio Male connector	231-654/019-000	WAGO	1	00L0291535	/10.4
-X20.2	Connettore femmina Female connector	231-324/037-000	WAGO	1	00L0291536	/10.4
-X2.1	Connettore femmina Female connector	231-316/037-000	WAGO	1	0001351462G	/10.4
-X2.2	Connettore maschio Male connector	231-646/019-000	WAGO	1	0001351460C	/10.4
-X5.1	Connettore maschio Male connector	231-646/019-000	WAGO	1	0001351460C	/10.4
-X5.2	Connettore femmina Female connector	231-316/037-000	WAGO	1	0001351462G	/10.4
-SB0	Pulsanti luminosi, piatto, bianco, ad impulso, simbolo accensione Illuminated pushbutton actuator, flush, white, spring-return	M22-SIMB-ACC	Eaton Moeller	1	0001309709A	/10.5
-SB0	Supporto per contatti Fixing adapter	M22-A	Eaton Moeller	1	0001300700A	/10.5
-SB0	Elementi di contatto, 1NA, Fissaggio frontale, Cage clamp Contact element, 1N/O, Front fixing, Cage clamp	M22-CK10	Eaton Moeller	1	0001300024F	/10.5
-SB0	Elementi LED, bianco, Fissaggio frontale, Cage clamp LED element, white, Front fixing, Cage clamp	M22-CLED-W	Eaton Moeller	1	0001300926A	/10.5
-K0	Relé ad impulso, 2contatti NO 16A,24Vdc Modular step relay, double phase switch 2 NO (DPST-NO) - DC - 24 V - AgNi	20.22.9.024.0000	Finder	1	0001304323E	/10.6
-FU3	Fusibile Cilindrico 5x20 2A Rapido Cylindrical Fuse 5x20 2A Fast	5x20 RAP 2A 250VAC		1	0001304031	/10.7
-FU3	Morsetto portafusibile Terminal block for fuse	2002-1611	WAGO	1	00L0074329H	/10.7
-U1	Scheda Card	S6-ROBOT	Robopac	1	1430300180	/11.0
-X16.1	Connettore maschio Male connector	231-638/019-000	WAGO	1	0001351467H	/11.2
-X4.2	connettore maschio (per morsetti componibili) MALE CONNECTOR	231-642/019-000	WAGO	1	0001351528	/11.5
-U3	Scheda Card	PRESTIRO 2M ROBOT S6	Robopac	1	1430300181	/11.5
-SB1	Pulsanti per arresto d'emergenza, Sblocco a rotazione Emergency-Stop actuator, non-illuminated , turn to release	ZB4-BS844	Schneider Electric	1	0001309191L	/14.3
-SB1	Supporto per contatti Fixing adapter	ZB4-BZ009	Schneider Electric	1	0001309192B	/14.3
-SB1	Elementi di contatto, 1NA, Fissaggio frontale, A vite Contact element, 1N/O, Front fixing, Screw connection	ZBE101	Schneider Electric	1	0001309165E	/14.3
-SB1	Elementi di contatto, 1NC, Fissaggio frontale, A vite Contact element, 1N/C, Front fixing, Screw connection	ZBE-102	Schneider Electric	1	0001309166G	/14.3
-SB2	Pulsante, piatto, blu, ad impulso, simbolo Reset Pushbutton actuator, flush, blue, spring return, Reset symbol	M22-D-B SIMB-RESET	Eaton Moeller	1	0001309708H	/14.6
-SB2	Supporto per contatti Fixing adapter	M22-A	Eaton Moeller	1	0001300700A	/14.6
-SB2	Elementi di contatto, 1NA, Fissaggio frontale, Cage clamp Contact element, 1N/O, Front fixing, Cage clamp	M22-CK10	Eaton Moeller	2	0001300024F	/14.6
-K1	Contattore per trazione elettrica Contactor	ETL20PA2	Ravioli	1	0470300003	/14.8
-SB3	Pulsante, piatto, senza Capsule, ad impulso Pushbutton actuator, flush, without button plate, spring-return	M22-D-X	Eaton Moeller	1	0099000554E	/16.1
-SB3	Supporto per contatti Fixing adapter	M22-A	Eaton Moeller	1	0001300700A	/16.1
-SB3	Elementi di contatto, 1NA, Fissaggio frontale, Cage clamp Contact element, 1N/O, Front fixing, Cage clamp	M22-CK10	Eaton Moeller	1	0001300024F	/16.1
-SQ5	Finecorsa Limit switch	FR-1630-M1	Pizzato	1	0001309638L	/16.4
-B1	Fotocellula Light barrier	S6-5-C200	Datalogic	1	0001310154D	/16.6
-B1 Opt	Fotocellula Light barrier	S62-PA-2-M31-PP SV4761	Datalogic	1	00L0162782	/16.6



Description

Distinta articoli
Parts list

Code

3709301174

Date

15/01/2016

Total

40

Prev

4

Subs

5.1

Page

5

Machine

Mas Pvs

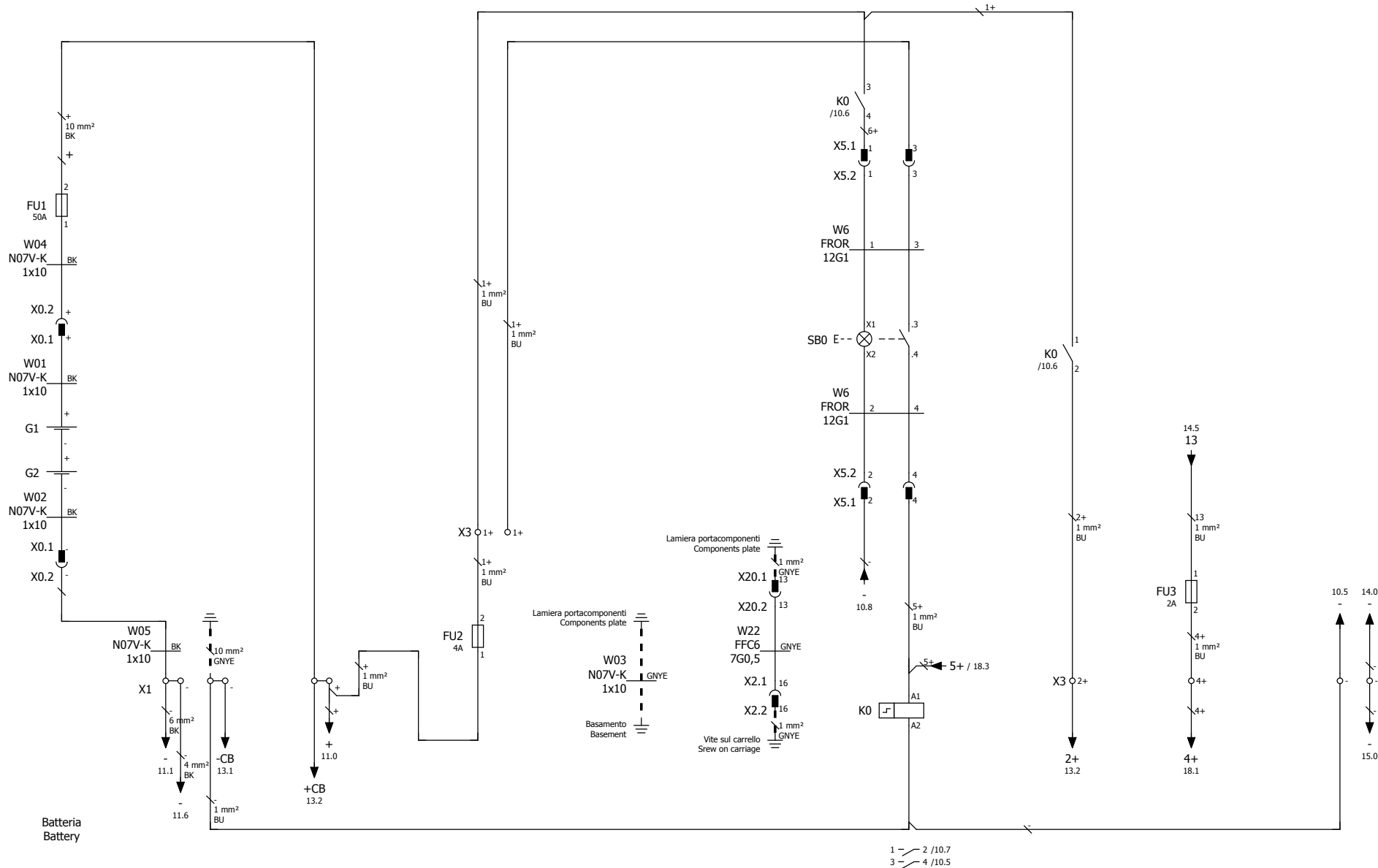

Description

Alimentazione
Power supply

Code 3709301174

Date 15/01/2016

Total 40

Prev 5.1

Subs 11

Page

Machine

Mas Pvs

10

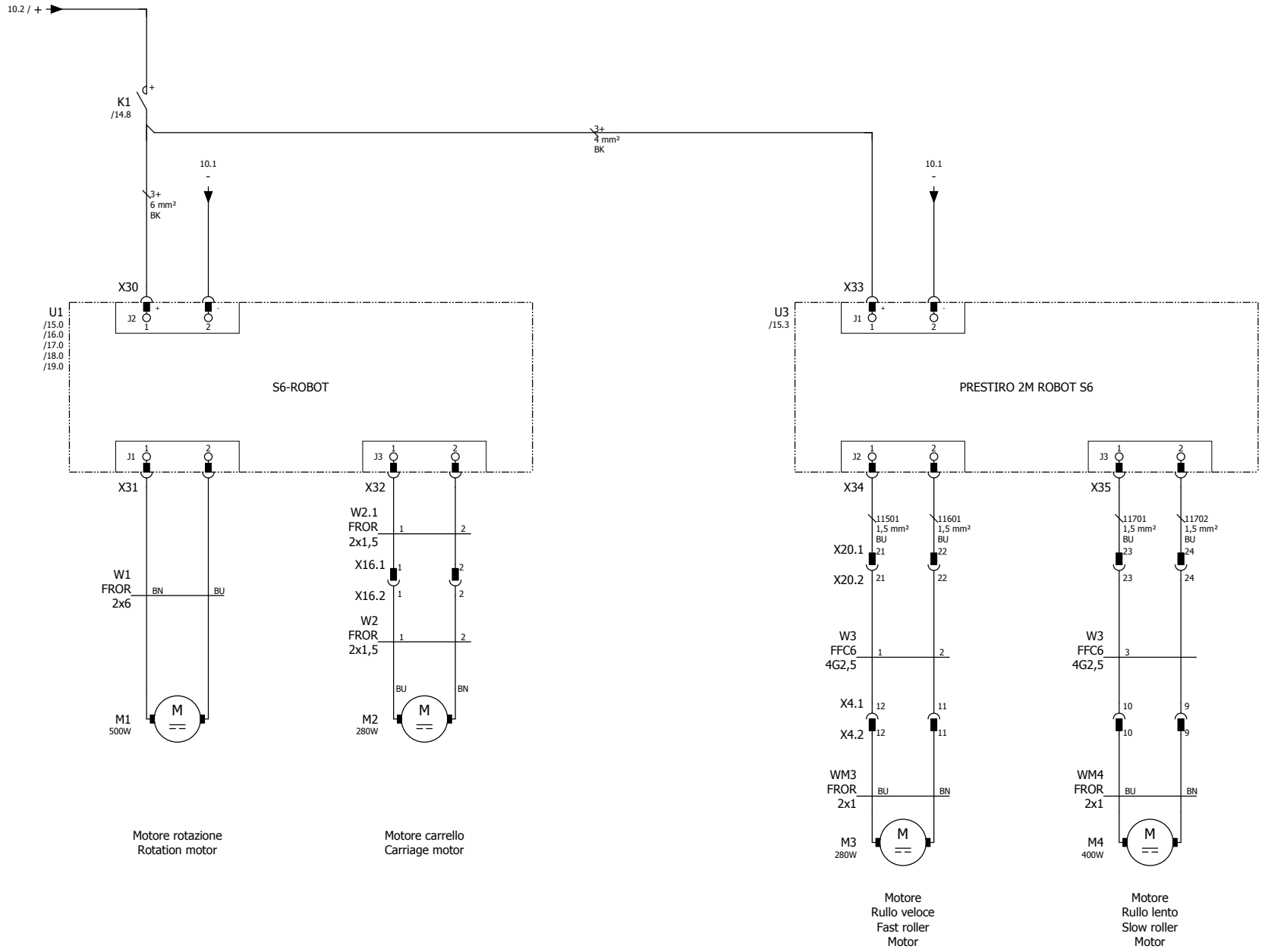

Description
Circuito di potenza
Power circuit

Code	3709301174	Date	15/01/2016	Total	40	Prev	10	Subs	13	Page	11
Machine	Mas Pvs										

Fusibile per linea cliente
Fuse for customer's line

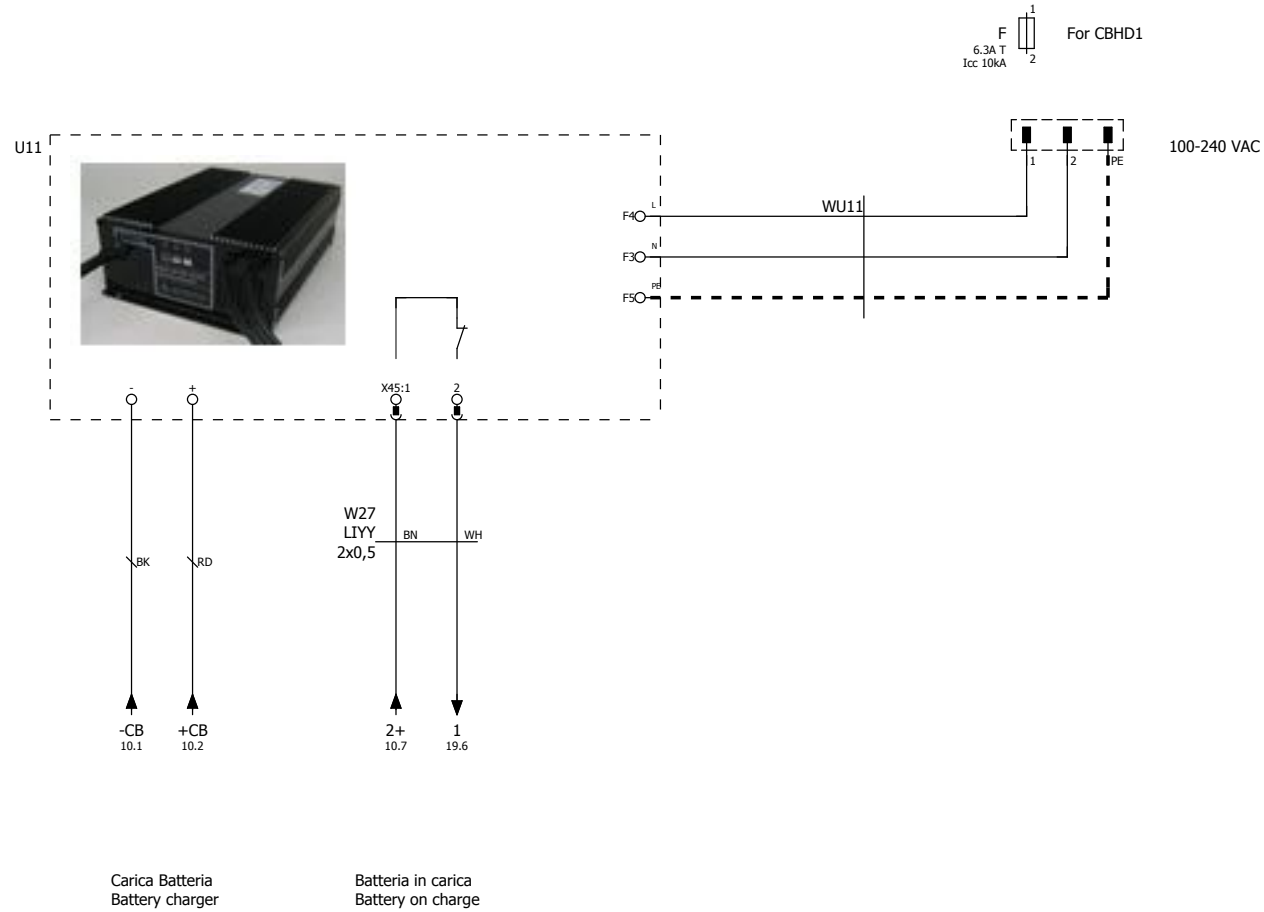

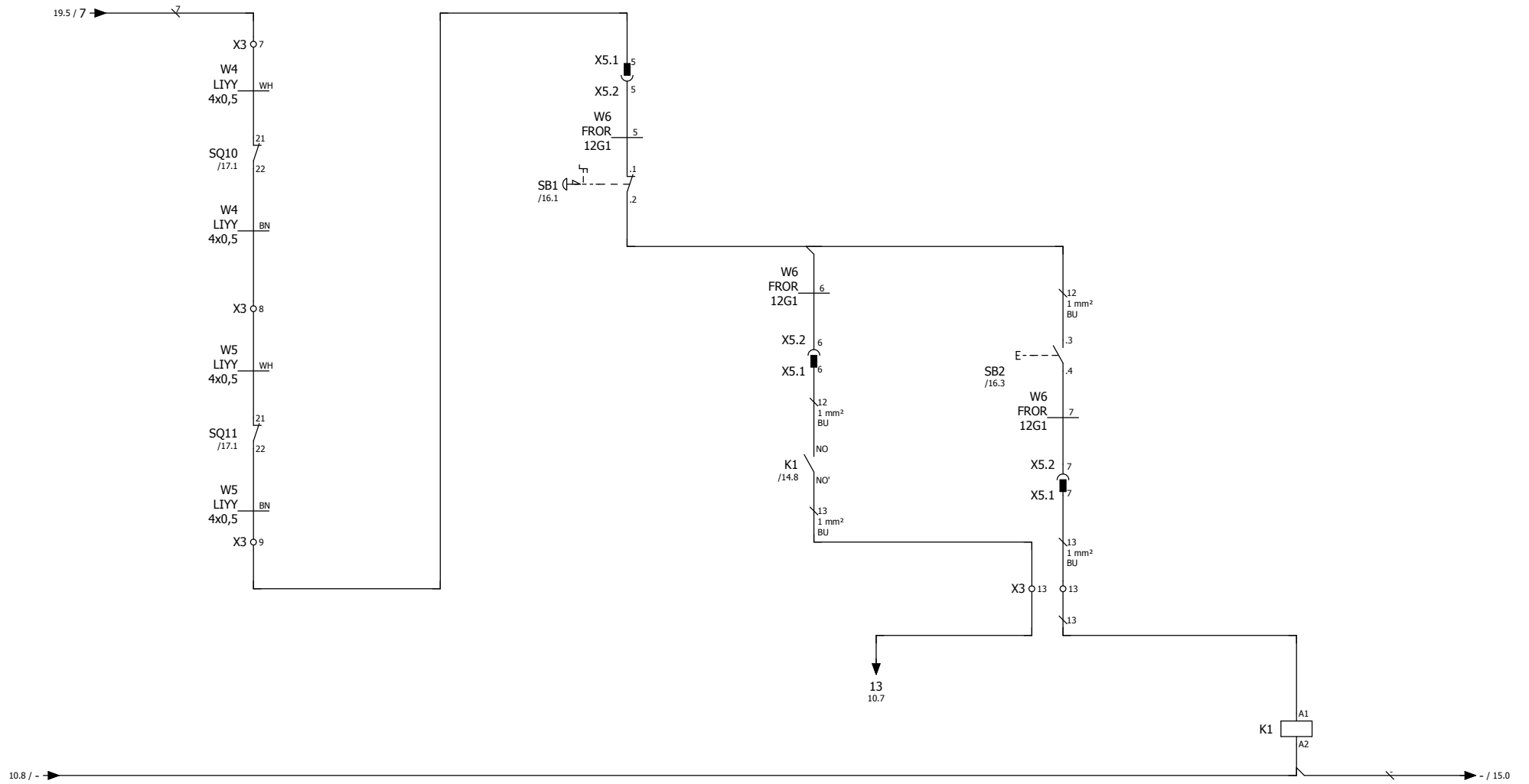

Emergenza paraurti
Schock-absorber emergency

Emergenza
Emergency stop

RESET
RESET

Contattore emergenza
Emergency contactor

+ ⚡ /11.1
NO - NO' /14.5
NC - NC /17.0

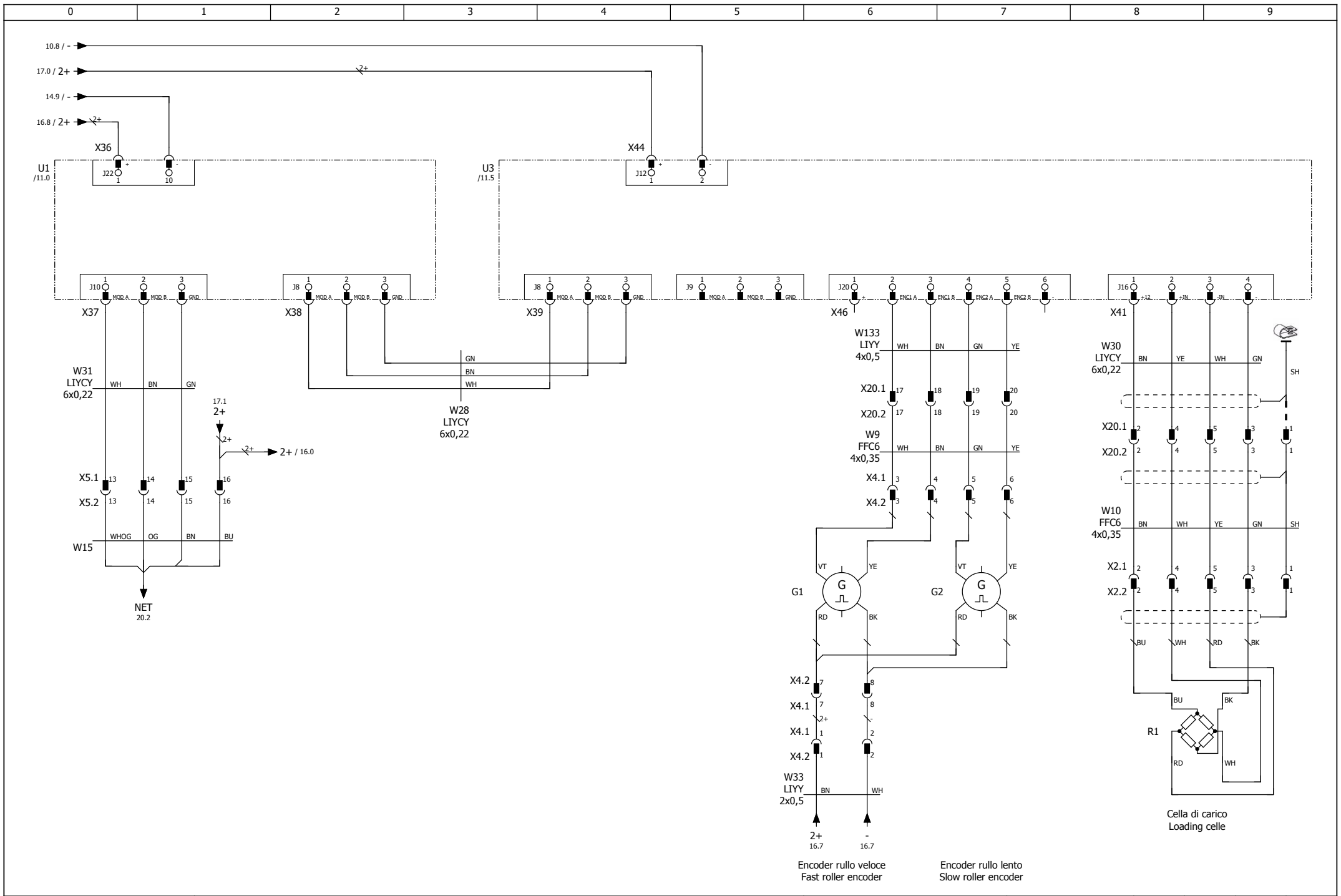

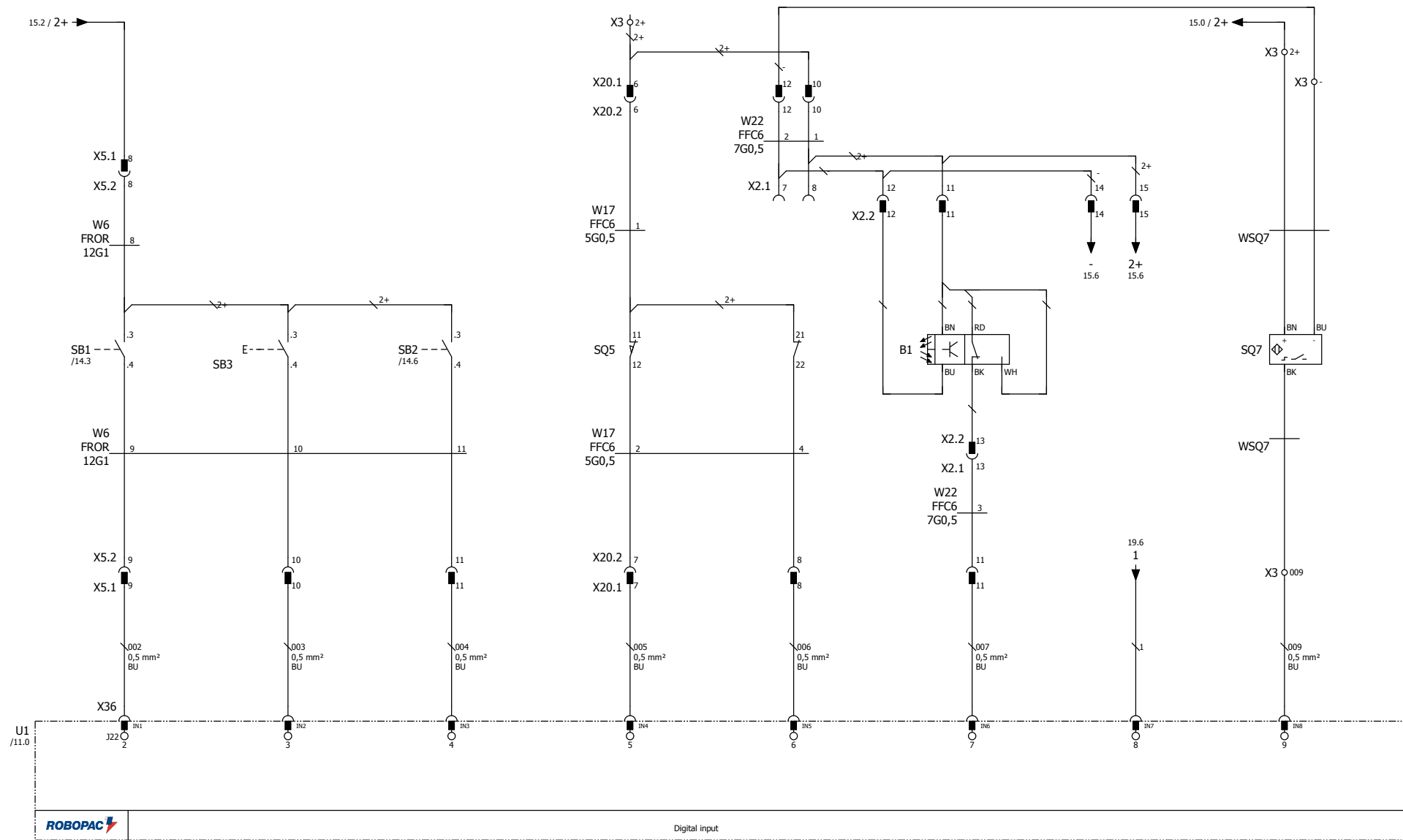

Digital Input

Emergenza
Emergency stop

Start

RESET
RESET

Fincorsa alto
High Limit switch

Fincorsa basso
Down Limit switch

Fotocellula altezza prodotto
Height product photocelle

Contaspigoli
Corner counter



Description

Circuito ausiliario
Auxiliary circuit

Code 3709301174

Date 15/01/2016

Total 40

Prev 15

Subs 17

Page

Machine

Mas Pvs

16

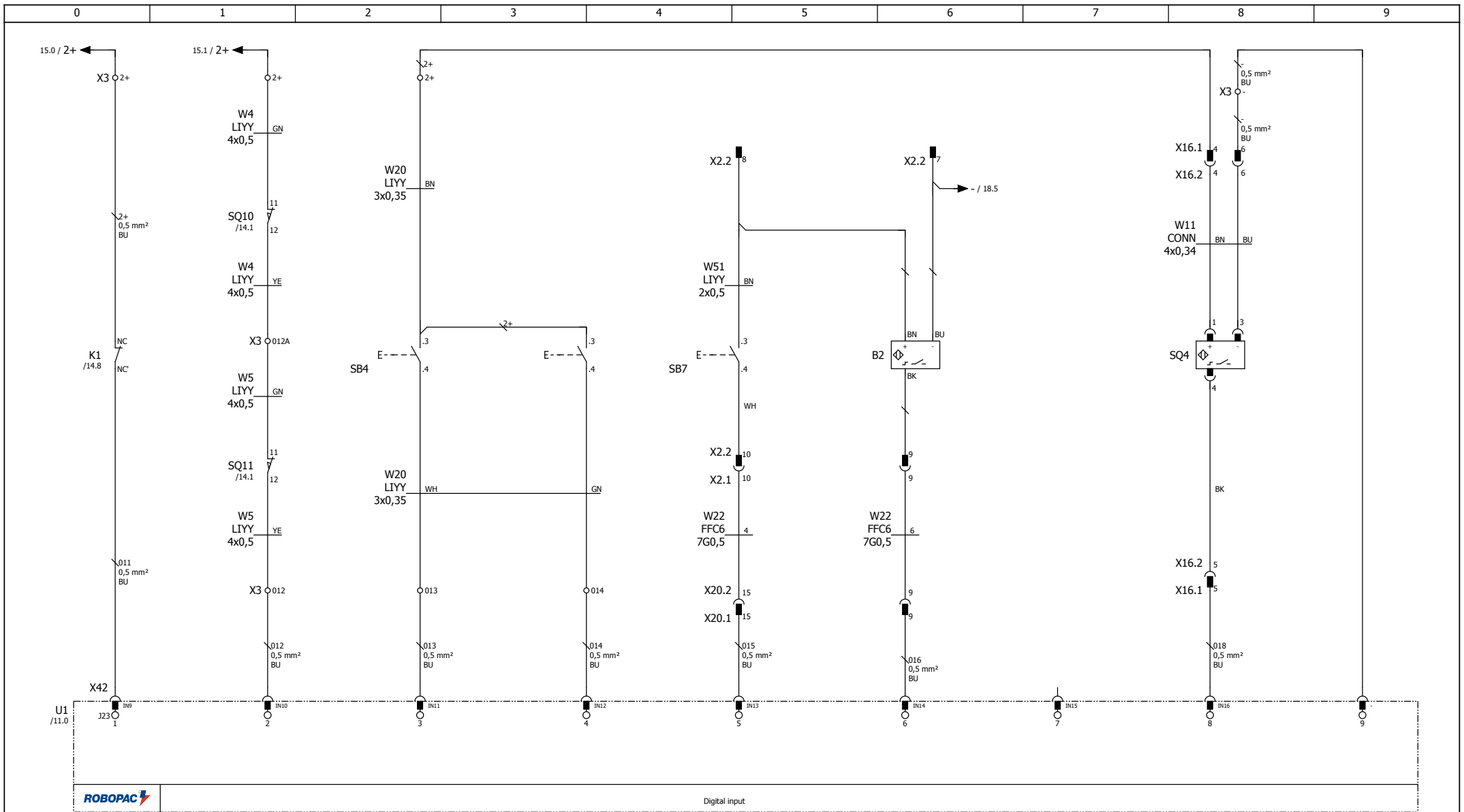

Digital input

Retroazione emergenza
Emergency feedback

Emergenza paraurti
Schock-absorber emergency

Manuale avanti
Forward manual

Manuale indietro
Backward manual

Pulsante svolgimento film
Film unrolling button

Sensore carter carrello
Carriage carter sensor

Sensore motore carrello
Carriage motor sensor



Description
Circuito ausiliario
Auxiliary circuit

Code	3709301174	Date	15/01/2016	Total	40	Prev	16	Subs	18	Page	17
Machine	Mas Pvs										

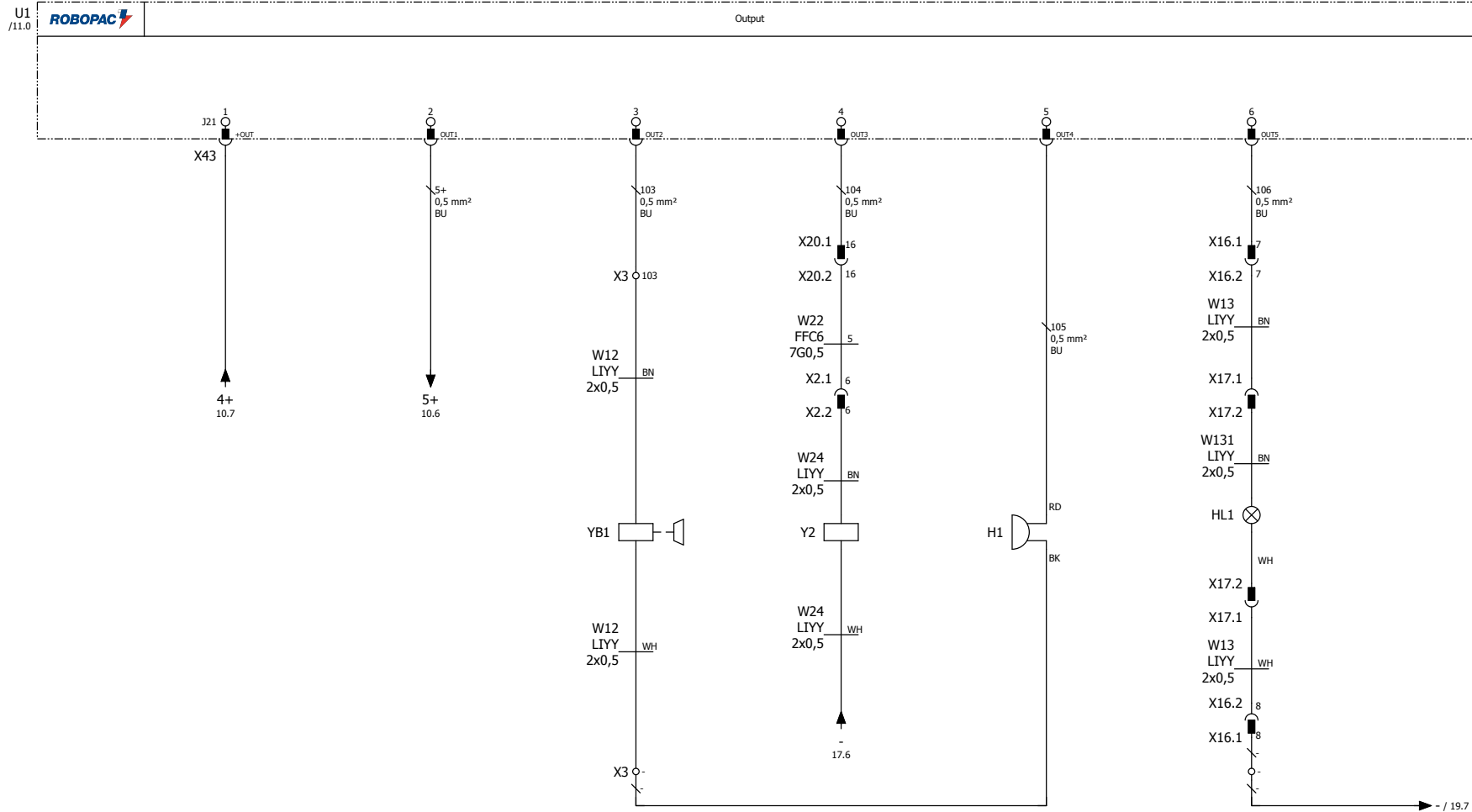

Alimentazione uscite
Output power supply

Uscita autospegnimento
Automatic turn-off
output

Freno rotazione
Rotation brake

Taglio film
Film cut
(Optional)

Sirena
Siren

Lampada
Lamp

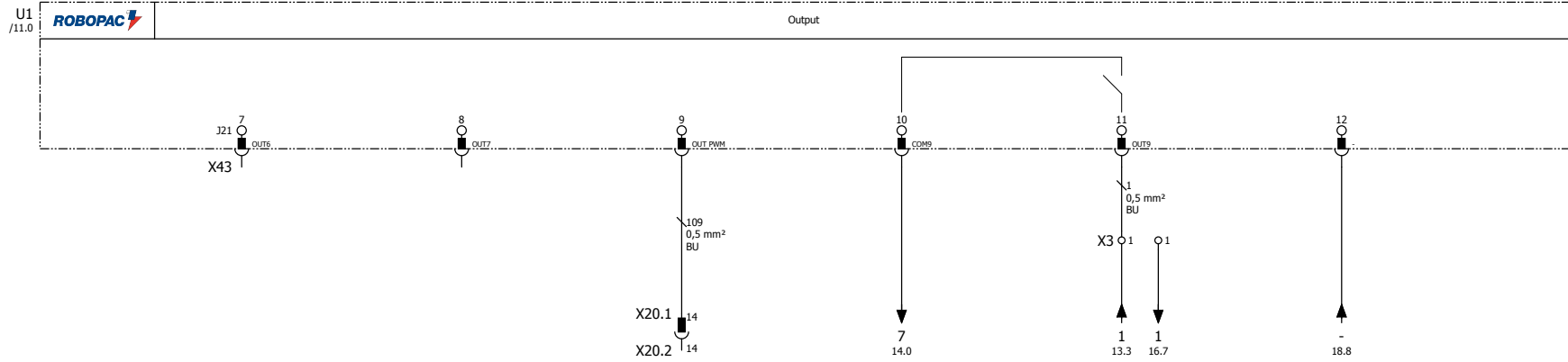

Retroazione emergenza
Emergency feedback

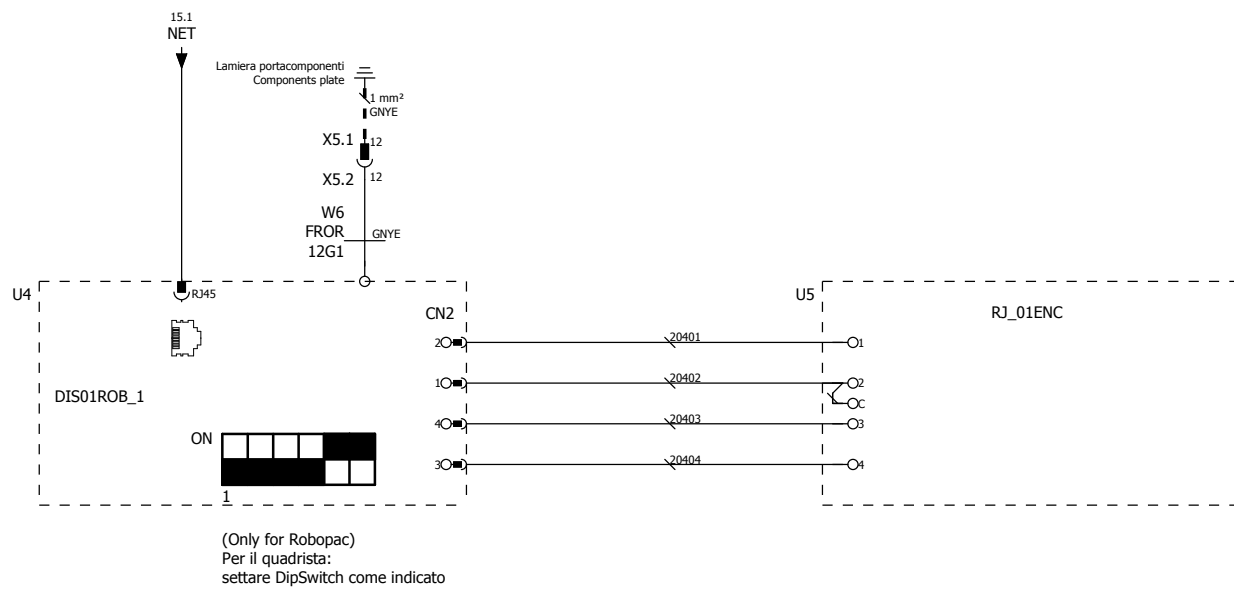

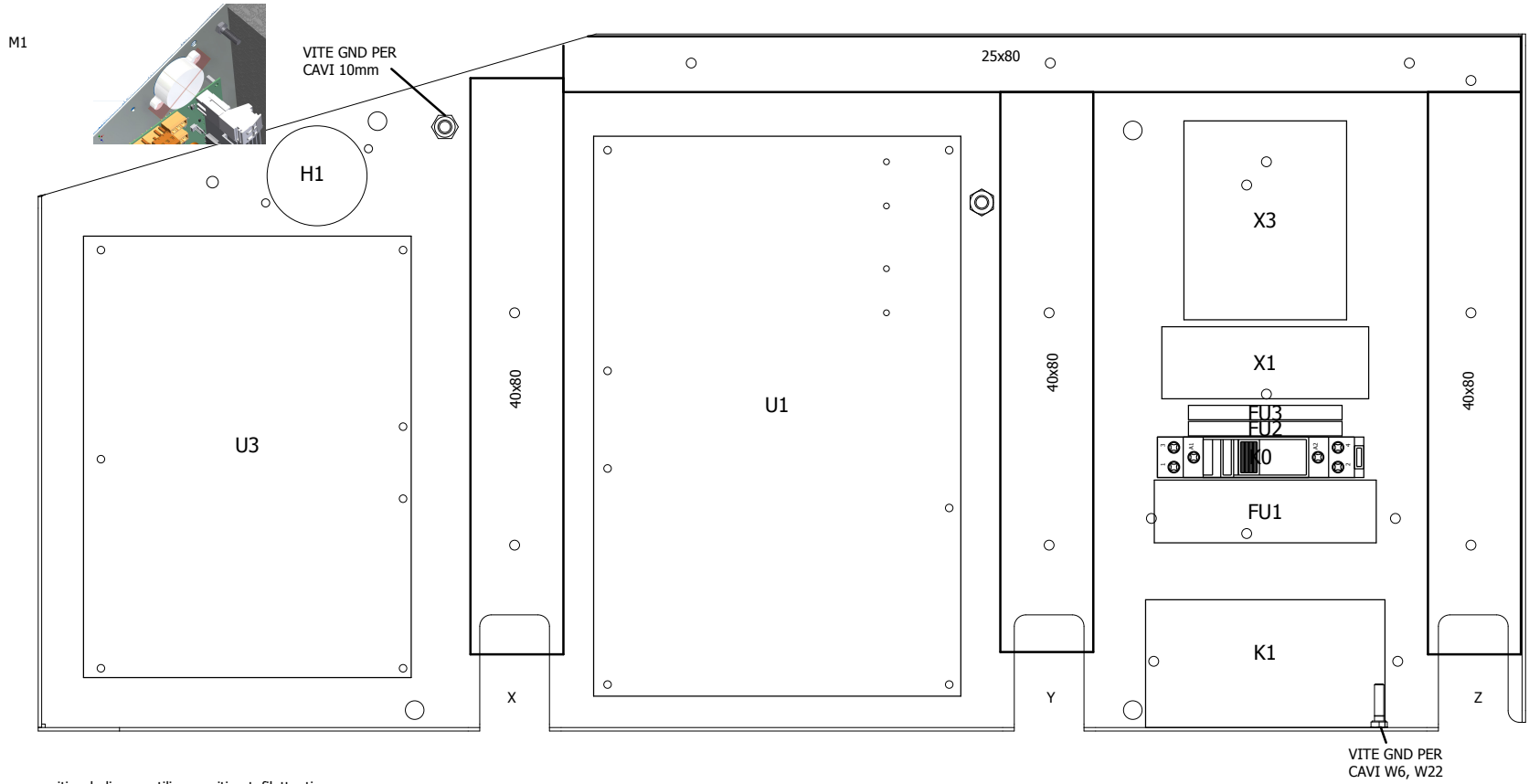

Fissare i componenti alla lamiera con viti e dadi, non utilizzare viti autofilettanti.
 Per il fissaggio della schede elettroniche U1 e U3 fissare i distanziali alla lamiera e utilizzare dadi per fissare le schede ai distanziali.

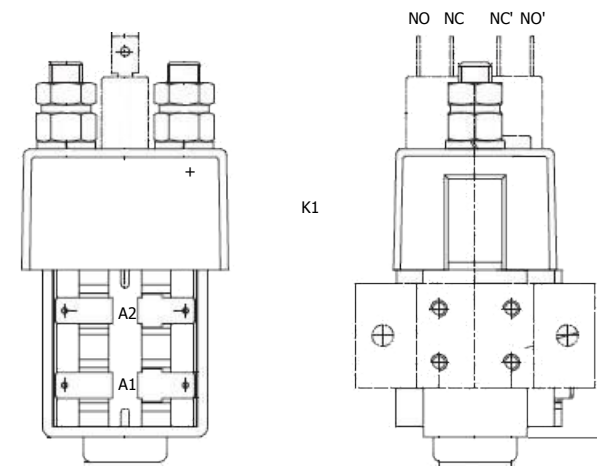

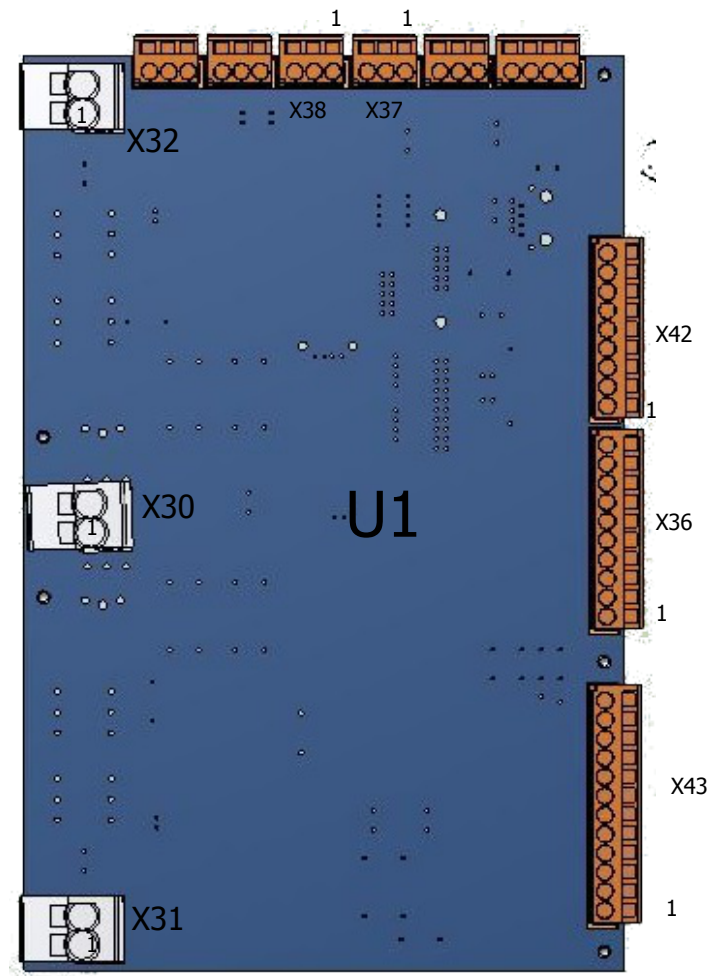
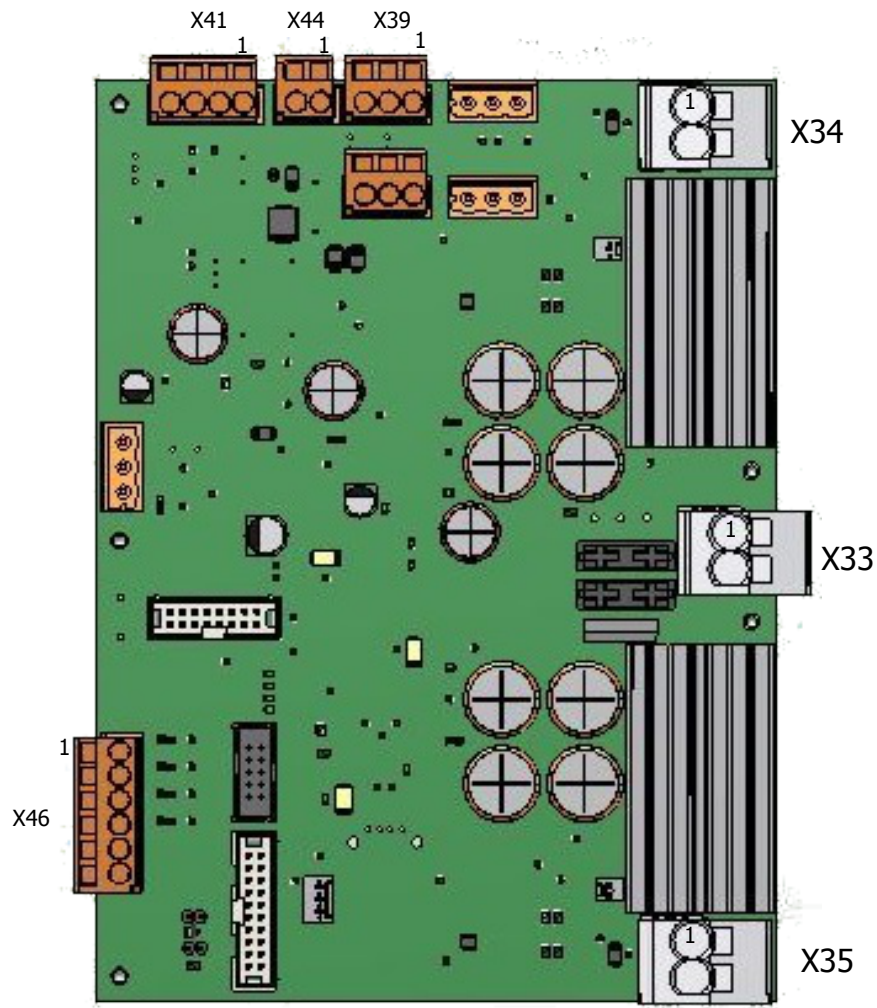

X5.1

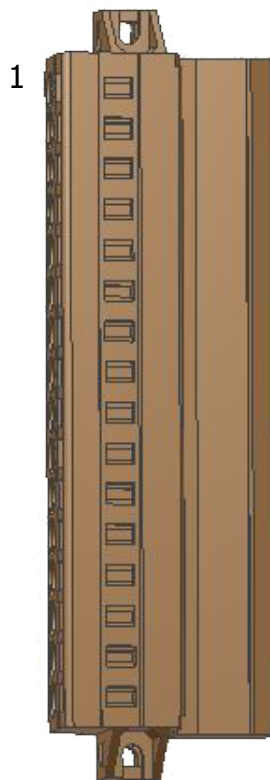

X16.1



X20.1

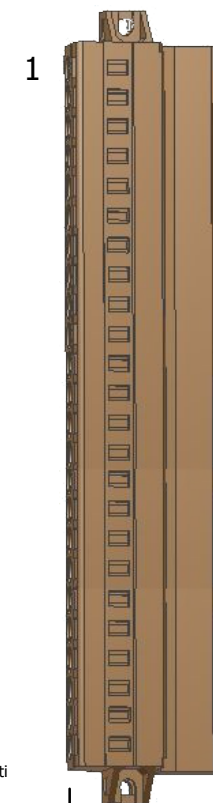

I cavi che arrivano ai connettori, devono avere una lunghezza di 60 cm dai fori di uscita della lamiera portacomponenti.
Per ogni connettore, raggruppare i fili in guaina intrecciata.

Sommario cavi

Cavo	Origine	N° Conduttori	Sezione	Capicorda origine	Spelatura origine (cm)	Lunghezza fuori cassetta (m)	Spelatura destinazione (cm)	Capicorda destinazione	Destinazione	Note
-W1	-X31	2	6 mm ²	--	7	Vedi distinta	10	Occhiello d=6	-M1	Foro uscita X
-W03		1	10 mm ²			0,85		Occhiello		Foro uscita X
-W04	-FU1	1	10 mm ²	Puntalino		1,2		--	-X0.2	Foro uscita Z
-W05	-X1	1	10 mm ²	--		1,2		--	-X0.2	Foro uscita Z
-W12	-X3	2	0,5 mm ²	--		1,6	10	Puntalino	-YB1	Foro uscita X
-WSQ7	-X3			--		1			-SQ7	Foro uscita X



Description

Sommario cavi
Cable overview

Schema allacciamento morsetti

Terminal-connection diagram

Destinazioni interne
Internal targets

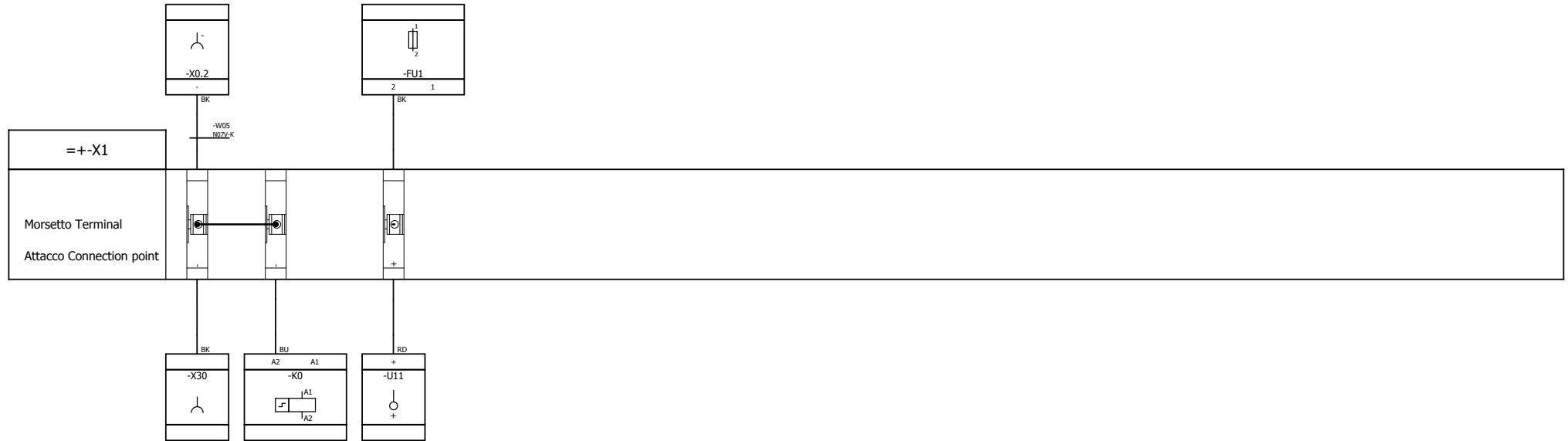

Destinazioni esterne
External targets



Description

Morsettiera di potenza
Power terminal strip

Code	3709301174	Date	15/01/2016	Total	40	Prev	24	Subs	26	Page	25
Machine	Mas Pvs										

Schema allacciamento morsetti

Terminal-connection diagram

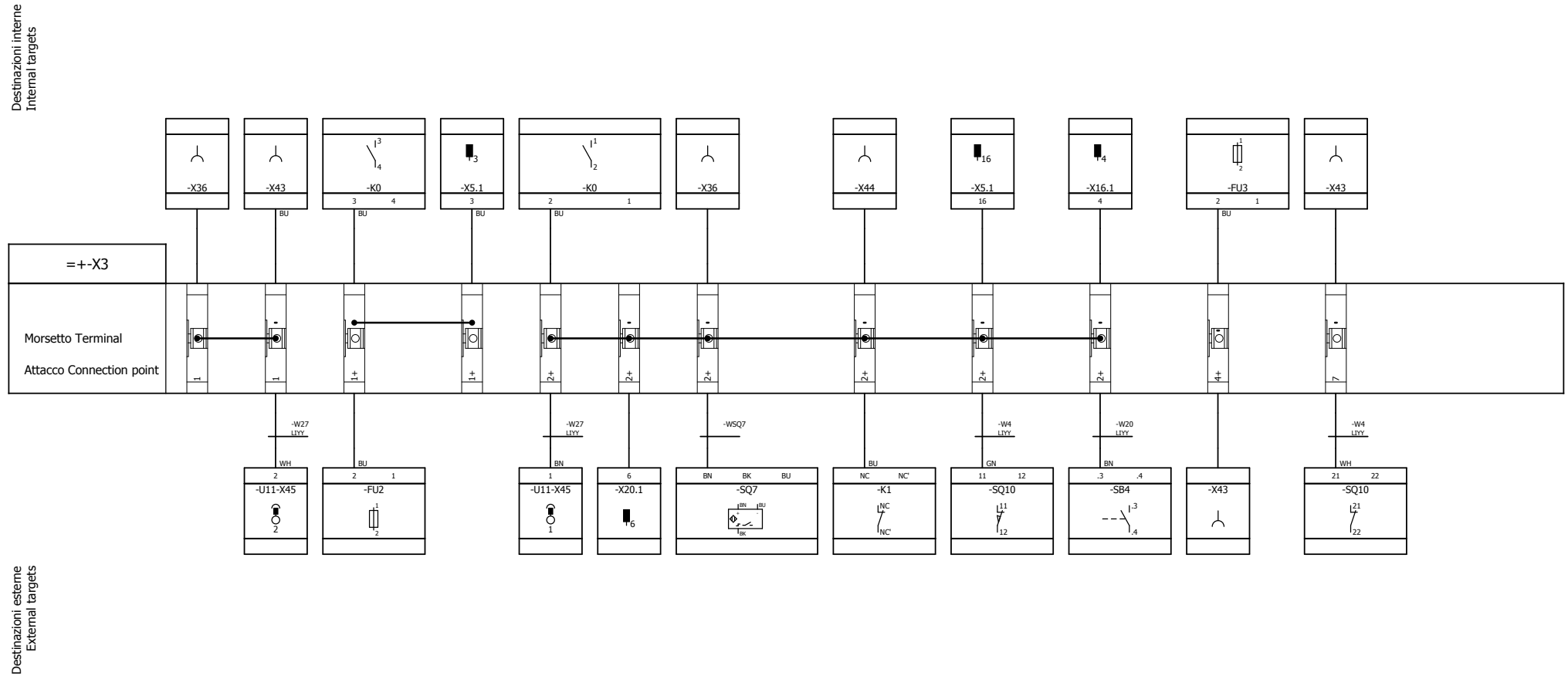

Description

Morsettiera generale
General terminal strip

Code

3709301174

Date

15/01/2016

Total

40

Prev

25

Subs

27

Page

26

Machine

Mas Pvs

Schema allacciamento morsetti

Terminal-connection diagram

Destinazioni interne
Internal targets

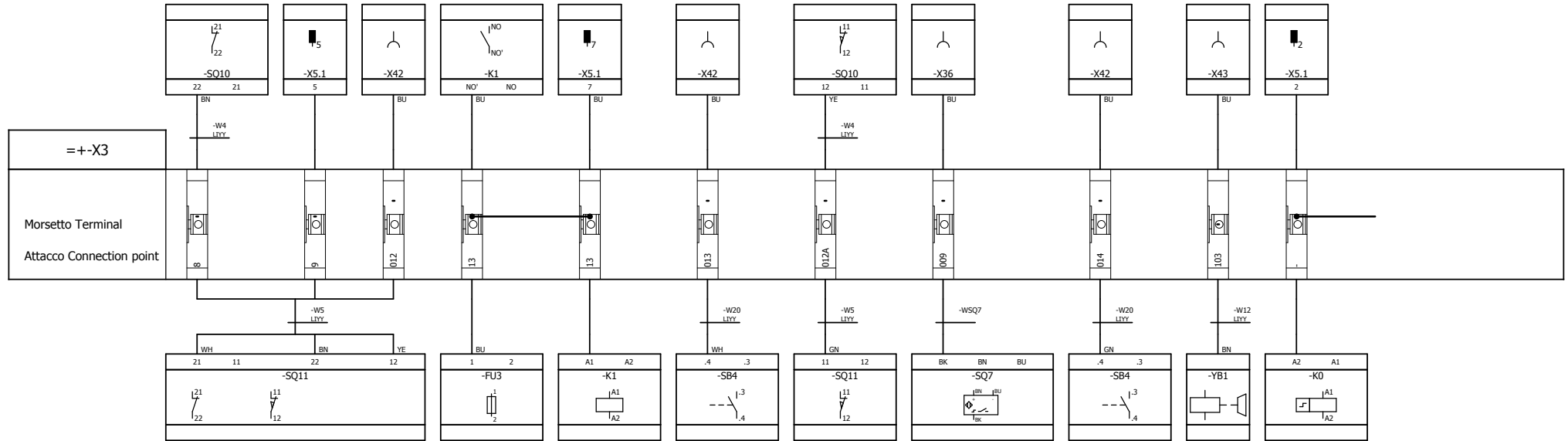

Destinazioni esterne
External targets



Description

Morsettiera generale
General terminal strip

Code 3709301174

Date 15/01/2016

Total 40

Prev 26

Subs 28

Page

Machine

Mas Pvs

27

Schema allacciamento morsetti

Terminal-connection diagram

Destinazioni interne
Internal targets

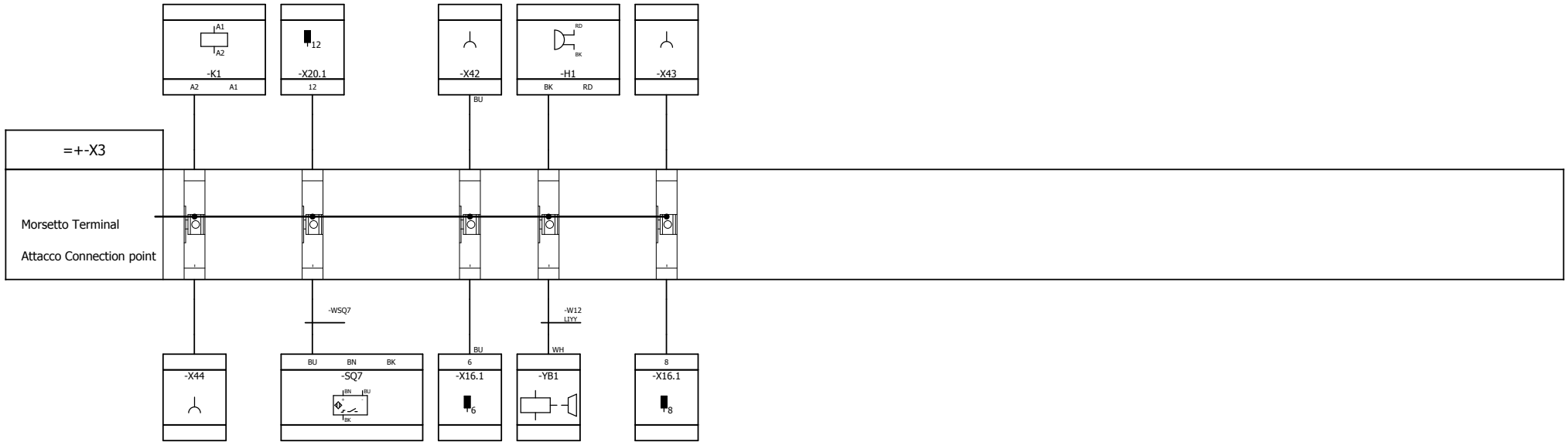

Destinazioni esterne
External targets



Description

Morsettiera generale
General terminal strip

Code	3709301174	Date	15/01/2016	Total	40	Prev	27	Subs	29	Page	28
Machine	Mas Pvs										

Schema allacciamento connettori

Pin-connection diagram

Destinazioni interne

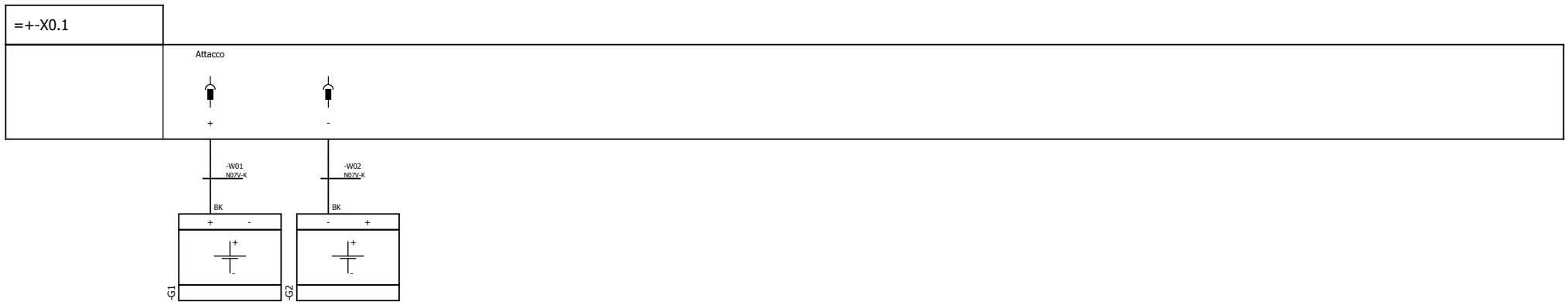

Destinazioni esterne



Description

Connettore batteria
Battery connectr

Code

3709301174

Date

15/01/2016

Total

40

Prev

28

Subs

30

Page

29

Machine

Mas Pvs

Schema allacciamento connettori Pin-connection diagram



Description

Connettore batteria
Battery connectr

Code	3709301174	Date	15/01/2016	Total	40	Prev	29	Subs	31	Page	30
Machine	Mas Pvs										

Schema allacciamento connettori Pin-connection diagram

Destinazioni interne

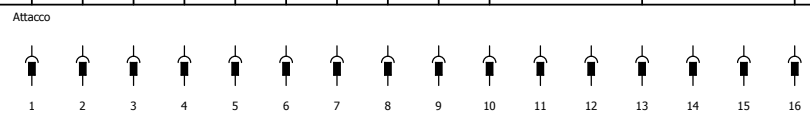
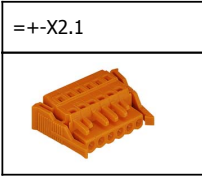
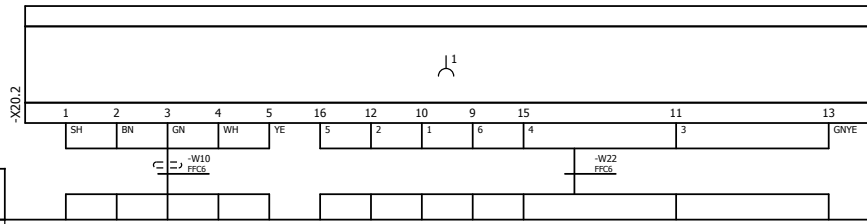

Destinazioni esterne



Description
Connettore carrello
Carriage connector

Code	3709301174	Date	15/01/2016	Total	40	Prev	30	Subs	32	Page	31
Machine	Mas Pvs										

Schema allacciamento connettori Pin-connection diagram

Destinazioni interne

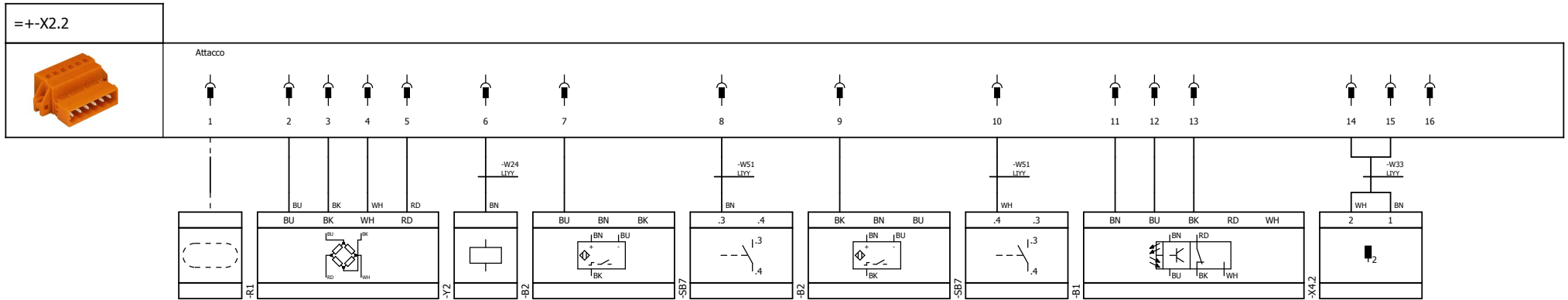

Destinazioni esterne



Description
**Connettore carrello
Carriage connector**

Code	3709301174	Date	15/01/2016	Total	40	Prev	31	Subs	33	Page	32
Machine	Mas Pvs										

Schema allacciamento connettori Pin-connection diagram

Destinazioni interne

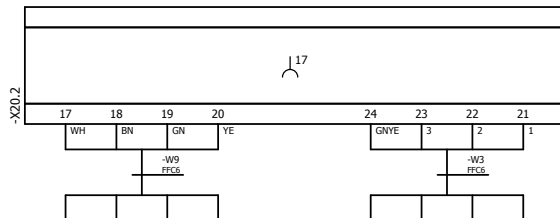

= + -X4.1



Destinazioni esterne



Description
Connettore motore carrello
Carriage motors connector

Code	3709301174	Date	15/01/2016	Total	40	Prev	32	Subs	34	Page	33
Machine	Mas Pvs										

Schema allacciamento connettori

Pin-connection diagram

Destinazioni interne

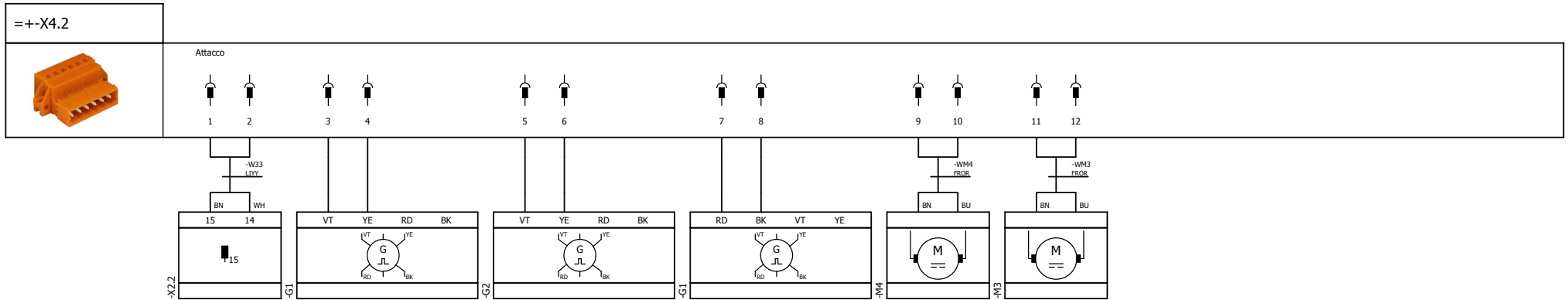

Destinazioni esterne



Description

Connettore motore carrello
Carriage motors connector

Code

3709301174

Date

15/01/2016

Total

40

Prev

33

Subs

35

Page

34

Machine

Mas Pvs

Schema allacciamento connettori

Pin-connection diagram

Destinazioni interne

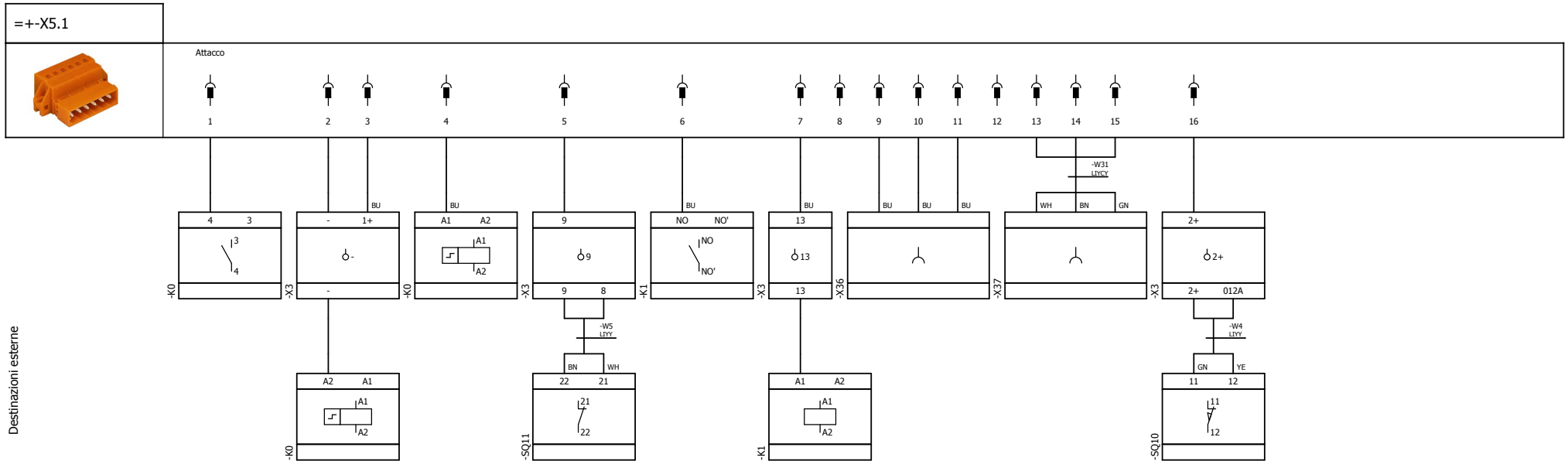

Destinazioni esterne



Description

Connettore pulsantiera
Push button connector

Code

3709301174

Date

15/01/2016

Total

40

Prev

34

Subs

36

Page

35

Machine

Mas Pvs

Schema allacciamento connettori

Pin-connection diagram

Destinazioni interne

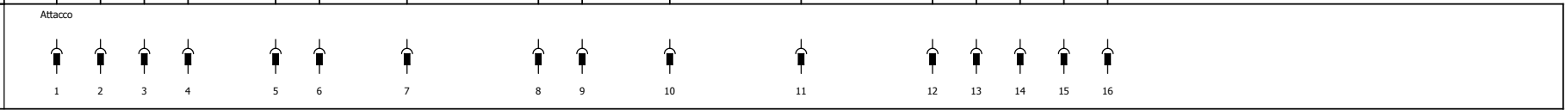
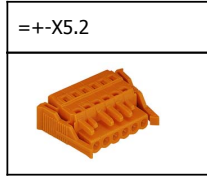
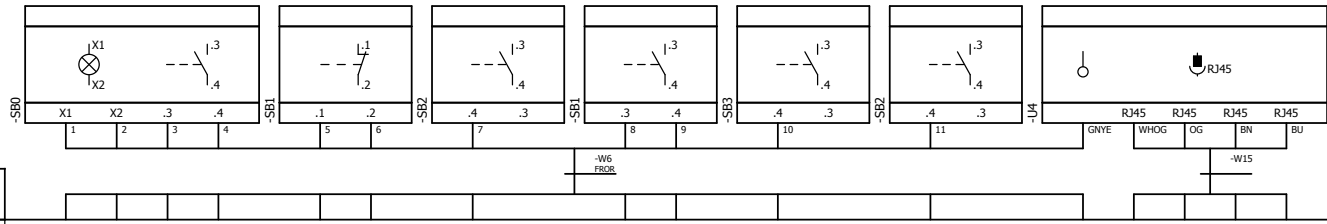

Destinazioni esterne



Description

Connettore pulsantiera
Push button connector

Code

3709301174

Date

15/01/2016

Total

40

Prev

35

Subs

37

Page

36

Machine

Mas Pvs

Schema allacciamento connettori

Pin-connection diagram

Destinazioni interne

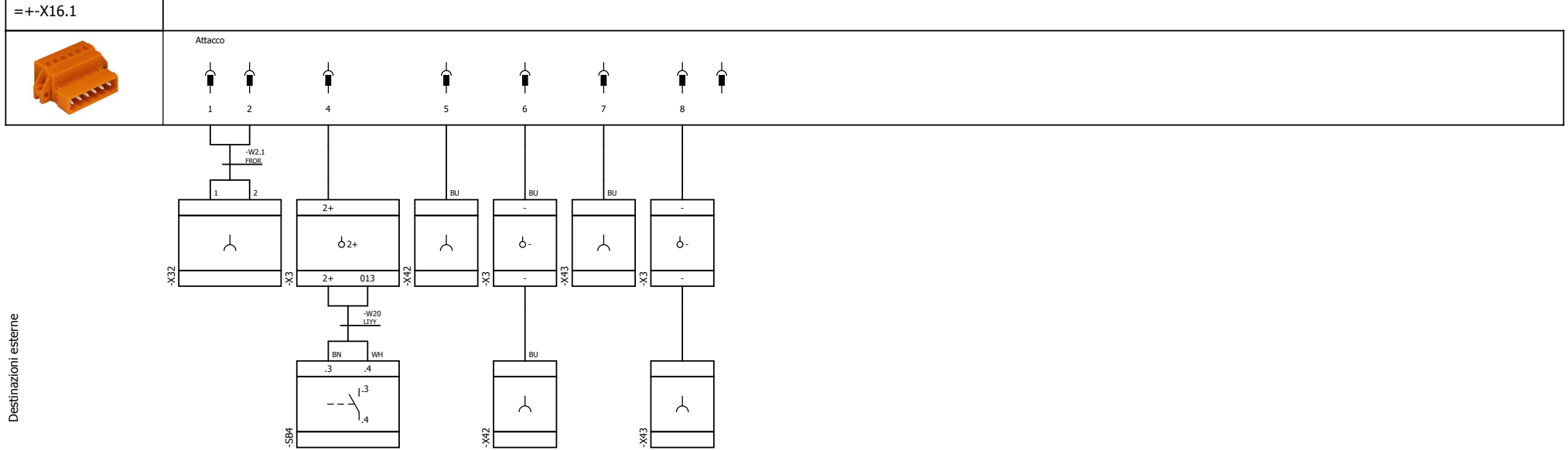

Destinazioni esterne



Description

Connettore palo
Mast connector

Code

3709301174

Date

15/01/2016

Total

40

Prev

36

Subs

38

Page

37

Machine

Mas Pvs

Schema allacciamento connettori Pin-connection diagram

Destinazioni interne

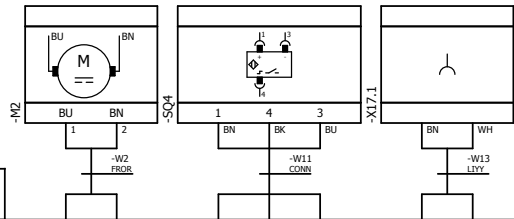

= + -X16.2



Attacco

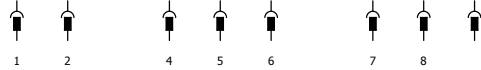

Destinazioni esterne



Description

Connettore palo
Mast connector

Code

3709301174

Date

15/01/2016

Total

40

Prev

37

Subs

39

Page

38

Machine

Mas Pvs

Schema allacciamento connettori

Pin-connection diagram

Destinazioni interne



Destinazioni esterne



Description

Connettore lampeggiatore
Lamp connector

Code

3709301174

Date

15/01/2016

Total

40

Prev

38

Subs

40

Page

39

Machine

Mas Pvs

Schema allacciamento connettori

Pin-connection diagram

Destinazioni interne

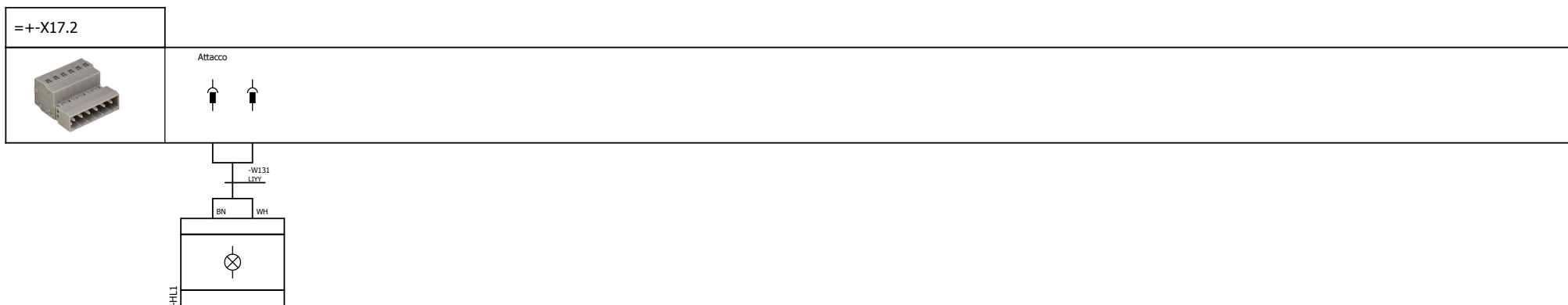

Destinazioni esterne



Description

Connettore lampeggiatore
Lamp connector

Code

3709301174

Date

15/01/2016

Total

40

Prev

39

Subs

41

Page

40

Machine

Mas Pvs

Schema allacciamento connettori Pin-connection diagram

Destinazioni interne

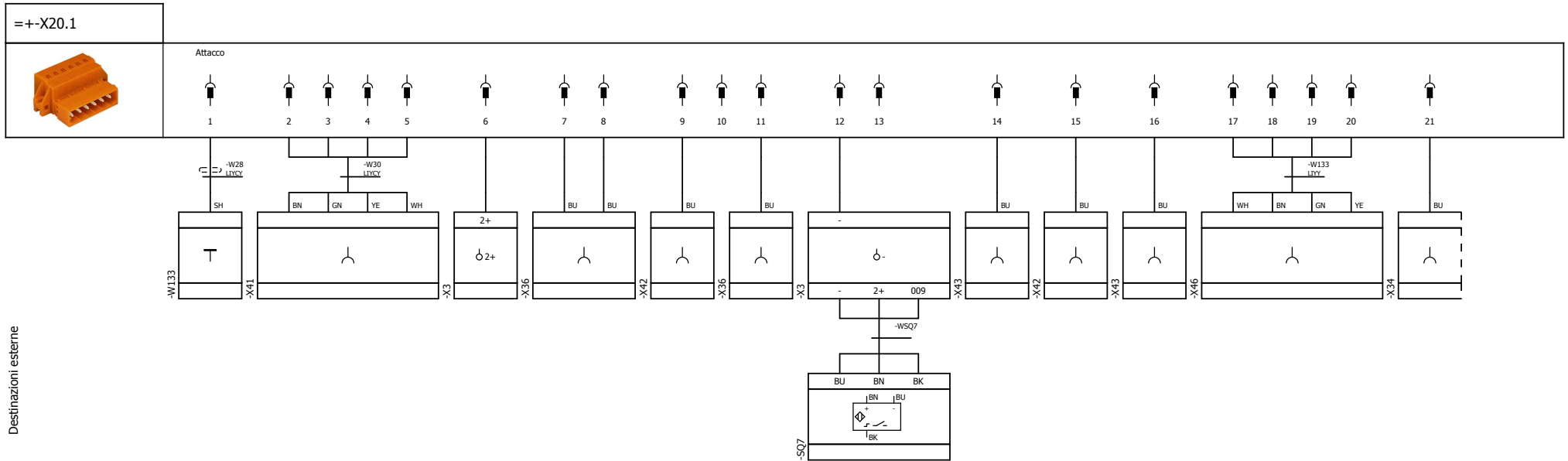

Destinazioni esterne



Description

Connettore cat.p.cavo
Connettore cat.p.cavo

Code

3709301174

Date

15/01/2016

Total

40

Prev

40

Subs

41.a

Page

41

Machine

Mas Pvs

Schema allacciamento connettori

Pin-connection diagram

Destinazioni interne

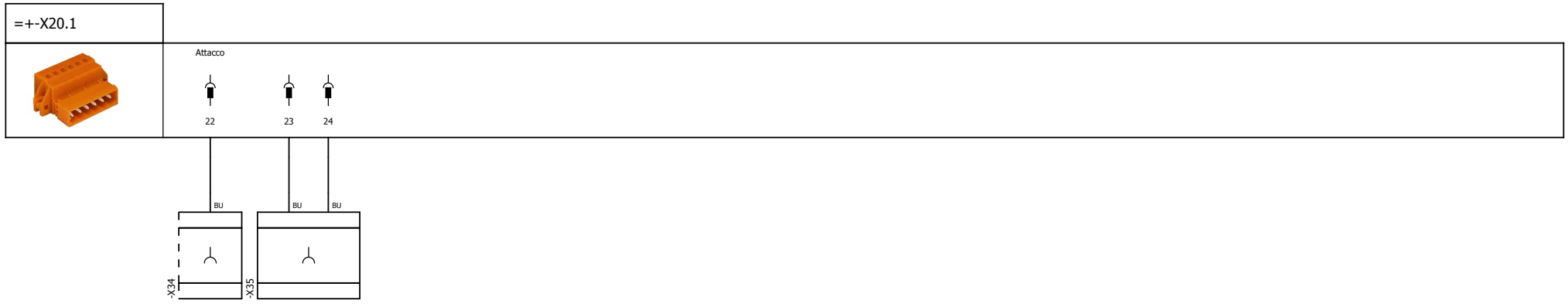

Destinazioni esterne



Description

Connettore cat.p.cavo
Connettore cat.p.cavo

Code	3709301174	Date	15/01/2016	Total	40	Prev	41	Subs	42	Page	41.a
Machine	Mas Pvs										

Schema allacciamento connettori

Pin-connection diagram

Destinazioni interne

= +-X20.2

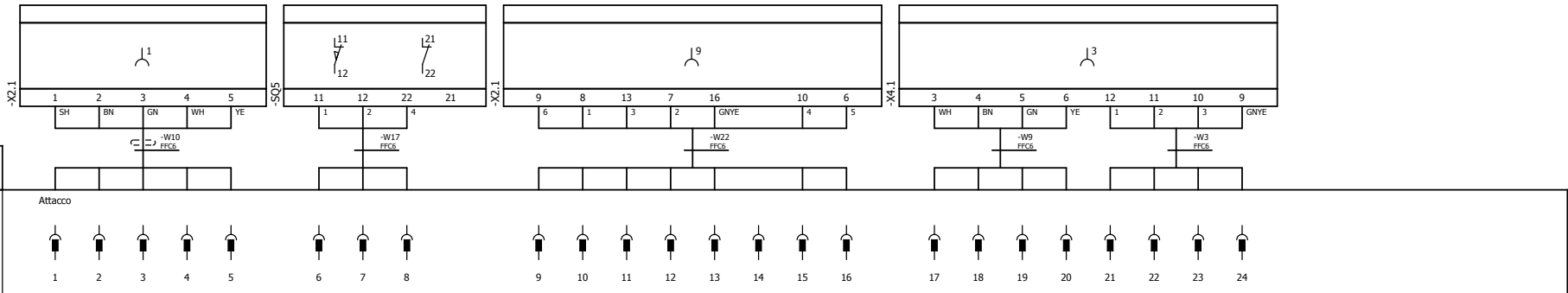
Destinazioni esterne



Description

Connettore cat.p.cavo
Connettore cat.p.cavo

Code

3709301174

Date

15/01/2016

Total

40

Prev

41.a

Subs

Page

Mas Pvs

42